

## 3.5mm Male to 3.5mm Male Test Cable Using VNA Test Cable Coax, LF Solder



### PE315

#### Configuration

- Connector 1: 3.5mm Male
- Connector 2: 3.5mm Male
- Cable Type: VNA Cable
- Coax Flex Type: Flexible

#### Features

- Max Frequency 26.5 GHz
- 77% Phase Velocity
- Double Shielded
- FEP Jacket

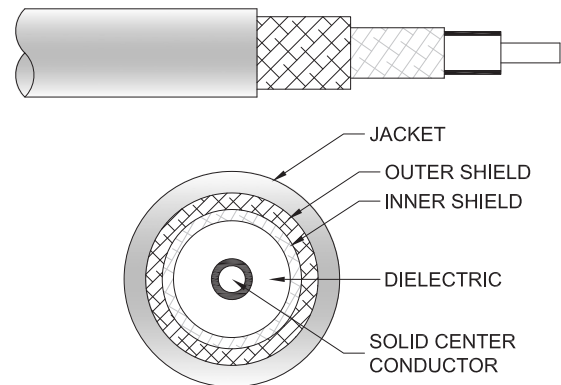

#### Applications

- General Purpose
- Test & Measurement
- Laboratory Use

#### Description

Pasternack's PE315 3.5mm male to 3.5mm male cable using VNA test cable coax is part of our full line of RF components available for same-day shipping. Pasternack's flexible RF cable assemblies are ideal for applications where tight bends and flexure are required. This Pasternack 3.5mm to 3.5mm cable assembly has a male to male gender configuration with 50 ohm flexible VNA cable coax. The PE315 3.5mm male to 3.5mm male cable assembly operates to 26.5 GHz. The double shielding of this Pasternack cable assembly provides excellent shielding effectiveness.

Custom versions of most RF cable assemblies can be built and shipped same day. Custom cable assembly lengths can be obtained by specifying the desired length on the web site at time of order or by contacting a sales representative. Other available RF cable assembly value added services include connector orientation or clocking, heat shrink booting and custom labeling. RF testing can also be performed to document the electrical performance of your cable assembly.

#### Electrical Specifications

Description	Minimum	Typical	Maximum	Units
Frequency Range	DC		26.5	GHz
Return Loss			-18	dB
Velocity of Propagation		77		%
Dielectric Withstanding Voltage (AC)			1,000	Vrms

#### Specifications by Frequency

Description	F1	F2	F3	F4	F5	Units
Frequency	1	10	18	26.5		GHz
Insertion Loss (Max.)	0.08	0.29	0.4	0.5		dB/ft
	0.26	0.95	1.31	1.64		dB/m

## 3.5mm Male to 3.5mm Male Test Cable Using VNA Test Cable Coax, LF Solder



### PE315

#### Specifications by Frequency

Description	F1	F2	F3	F4	F5	Units
Return Loss (Max.)	-30	-25	-20	-18		dB
Power Handling (Max.)		286				Watts

#### Electrical Specification Notes:

Shielding effectiveness > 100 dB at 1 GHz.

Insertion loss does not include the loss of the connectors.

Insertion loss is estimated as  $0.05 \times \sqrt{f(\text{GHz})}$  dB per connector.

#### Mechanical Specifications

##### Cable Assembly

Width/Diameter	0.47 in [11.94 mm]
Weight	0.42 lbs [190.51 g]

##### Cable

Cable Type	VNA Cable
Impedance	50 Ohms
Inner Conductor Type	Solid
Inner Conductor Material and Plating	Copper, Silver
Dielectric Type	PTFE
Number of Shields	2
Shield Layer 1	Silver Plated Copper Tape
Shield Layer 2	Silver Plated Copper Braid
Jacket Material	FEP
Repeated Minimum Bend Radius	1.38 in [35.05 mm]
Typical Flex Cycles	10,000

#### Connectors

Description	Connector 1	Connector 2
Type	3.5mm Male	3.5mm Male
Specification	MIL-STD-348	MIL-STD-348
Impedance	50 Ohms	50 Ohms
Configuration	Straight	Straight
Contact Material and Plating	Gold	Gold
Dielectric Type	PPO	PPO
Body Material and Plating	Passivated Stainless Steel	Passivated Stainless Steel
Coupling Nut Material and Plating	Passivated Stainless Steel	Passivated Stainless Steel
Hex Size	5/16 inch	5/16 inch
Torque	8 in-lbs 0.9 Nm	8 in-lbs 0.9 Nm

#### Environmental Specifications

Operating Range Temperature	-55 to +165 deg C
-----------------------------	-------------------

## 3.5mm Male to 3.5mm Male Test Cable Using VNA Test Cable Coax, LF Solder



### PE315

**Compliance Certifications** (see [product page](#) for current document)

#### Plotted and Other Data

Notes:  
Values at 25°C, sea level.

#### Typical Performance Data

#### How to Order

Part Number Configuration:

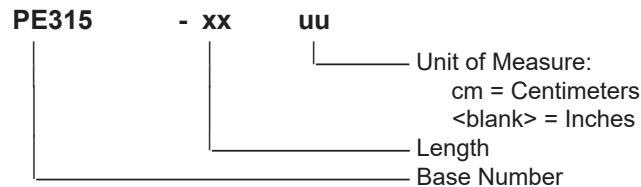

Example: PE315-12 = 12 inches long cable  
PE315-100cm = 100 cm long cable

3.5mm Male to 3.5mm Male Test Cable Using VNA Test Cable Coax, LF Solder from Pasternack Enterprises has same day shipment for domestic and International orders. Our RF, microwave and millimeter wave products maintain a 99.4% availability and are part of the broadest selection in the industry.

Click the following link (or enter part number in "SEARCH" on website) to obtain additional part information including price, inventory and certifications: [3.5mm Male to 3.5mm Male Test Cable Using VNA Test Cable Coax, LF Solder PE315](#)

URL: <https://www.pasternack.com/3.5mm-male-3.5mm-male-vna-cable-cable-assembly-pe315-p.aspx>

The information contained within this document is accurate to the best of our knowledge and representative of the part described herein. It may be necessary to make modifications to the part and/or the documentation of the part in order to implement improvements. Pasternack Enterprises reserves the right to make such changes as required. Unless otherwise stated, all specifications are nominal. Pasternack Enterprises does not make any representation or warranty regarding the suitability of the part described herein for any particular purpose, and Pasternack Enterprises does not assume liability arising out of the use of any part or document.

# PE315 CAD Drawing

3.5mm Male to 3.5mm Male Test Cable Using VNA Test Cable Coax, LF Solder

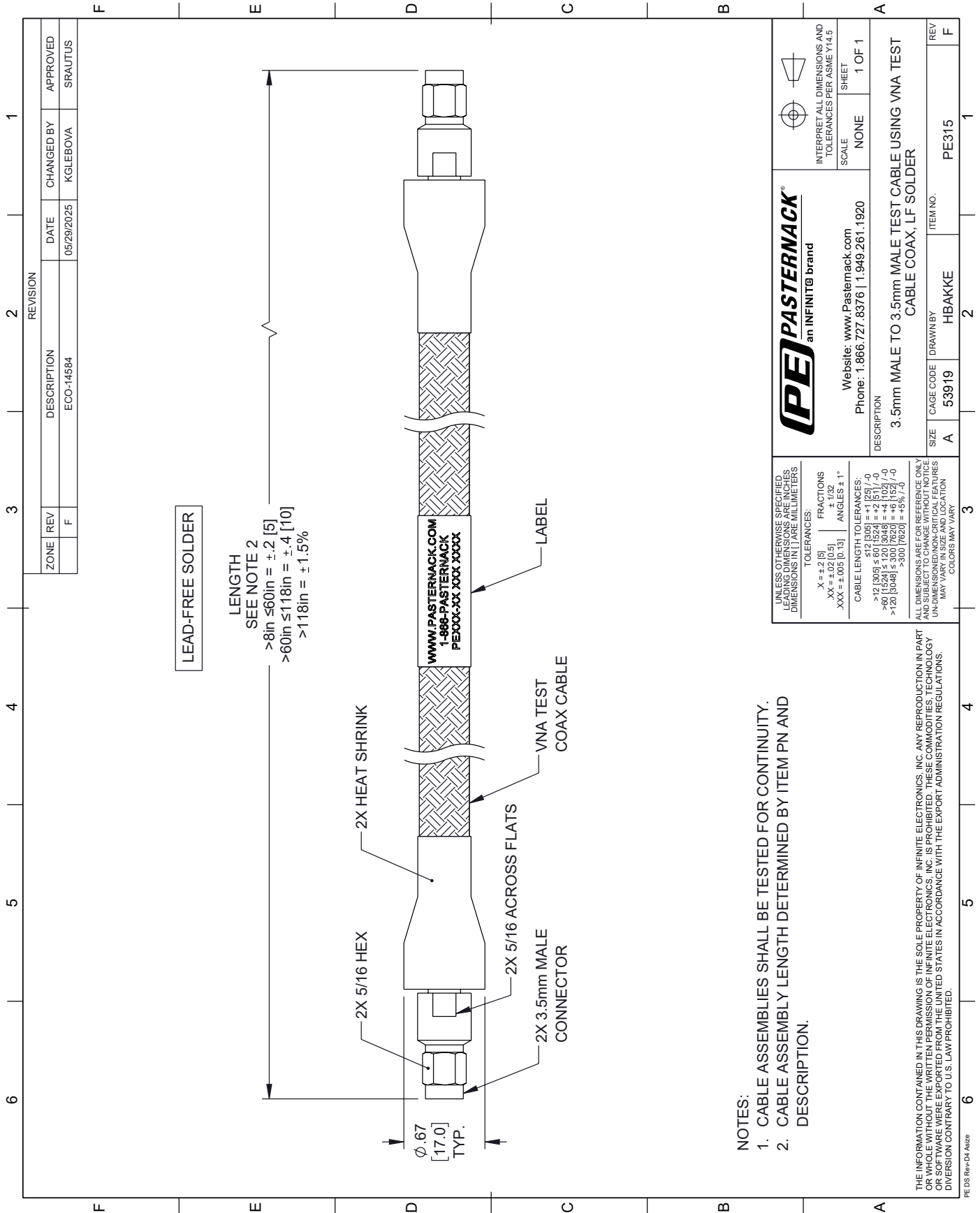

NOTES:  
 1. CABLE ASSEMBLIES SHALL BE TESTED FOR CONTINUITY.  
 2. CABLE ASSEMBLY LENGTH DETERMINED BY ITEM PN AND DESCRIPTION.

<b>PASTERNAK</b> an INFINITTE brand		INTERPRET ALL DIMENSIONS AND TOLERANCES PER ASME Y14.5 SCALE: NONE SHEET: 1 OF 1	
Website: <a href="http://www.Pasternack.com">www.Pasternack.com</a> Phone: 1.866.727.8376   1.949.261.1920		DESCRIPTION: <b>3.5mm MALE TO 3.5mm MALE TEST CABLE USING VNA TEST CABLE COAX, LF SOLDER</b>	
UNLESS OTHERWISE SPECIFIED LEADING DIMENSIONS ARE IN INCHES DIMENSIONS IN PAREMILLIMETERS TOLERANCES: .X = ±.2 [5] .XX = ±.02 [0.5] .XXX = ±.005 [0.13] FRACTIONS: ± 1/32 ANGLES: ± 1° CABLE LENGTH TOLERANCES: >12 [305] ≤ 60 [1524] = ±1 [25] /-0 >60 [1524] ≤ 120 [3048] = ±4 [102] /-0 >120 [3048] ≤ 300 [7620] = ±5 [127] /-0 >300 [7620] = ±5% /-0	ALL DIMENSIONS ARE FOR REFERENCE ONLY UNLESS OTHERWISE SPECIFIED. DIMENSIONS ON CRITICAL FEATURES MAY VARY IN SIZE AND LOCATION. COLORS MAY VARY.	SIZE: A CAGE CODE: 53919 DRAWN BY: HBAKKE	ITEM NO.: PE315

THE INFORMATION CONTAINED IN THIS DRAWING IS THE SOLE PROPERTY OF INFINITE ELECTRONICS, INC. ANY REPRODUCTION IN PART OR WHOLE WITHOUT THE WRITTEN PERMISSION OF INFINITE ELECTRONICS, INC. IS PROHIBITED. THESE COMMODITIES, TECHNOLOGY OR SOFTWARE WERE EXPORTED FROM THE UNITED STATES IN ACCORDANCE WITH THE EXPORT ADMINISTRATION REGULATIONS. DIVERSION CONTRARY TO U.S. LAW PROHIBITED.

PE DS Rev-04 A1822