

MMCX Plug to Push-On SMP Female Right Angle Low Loss Cable Using LMR-100 Coax with HeatShrink, LF Solder



PE3W11752LF/HS

Configuration

- Connector 1: MMCX Plug
- Connector 2: Push-On SMP Female Right Angle
- Cable Type: LMR-100A
- Coax Flex Type: Flexible

Features

- Max Frequency 3 GHz
- Shielding Effectivity > 90 dB
- 66% Phase Velocity
- Double Shielded
- PVC Jacket

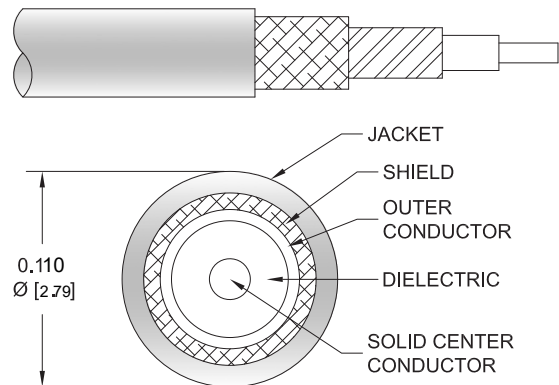

Applications

- General Purpose
- Laboratory Use

Description

Pasternack's PE3W11752LF/HS MMCX plug to SMP female push-on right angle cable using LMR-100 coax is part of our full line of RF components available for same-day shipping. Pasternack's flexible RF cable assemblies are ideal for applications where tight bends and flexure are required. This Pasternack MMCX to SMP cable assembly has a plug to female gender configuration with 50 ohm flexible LMR-100A coax. The PE3W11752LF/HS MMCX plug to SMP female cable assembly operates to 3 GHz. The right angle SMP interface on the LMR-100A cable allows for easier connections in tight spaces. The double shielding of this Pasternack cable assembly provides excellent shielding effectiveness of better than 90 dB.

Custom versions of most RF cable assemblies can be built and shipped same day. Custom cable assembly lengths can be obtained by specifying the desired length on the web site at time of order or by contacting a sales representative. Other available RF cable assembly value added services include connector orientation or clocking, heat shrink booting and custom labeling. RF testing can also be performed to document the electrical performance of your cable assembly.

Electrical Specifications

Description	Minimum	Typical	Maximum	Units
Frequency Range	DC		3	GHz
VSWR			1.4:1	
Velocity of Propagation		66		%
RF Shielding	90			dB
Group Delay		1.54 [5.05]		ns/ft [ns/m]
Capacitance		30.8 [101.05]		pF/ft [pF/m]
Inductance		0.077 [0.25]		uH/ft [uH/m]
DC Resistance Inner Conductor		81 [265.75]		Ohms/1000ft [Ohms/Km]
DC Resistance Outer Conductor		9.5 [31.17]		Ohms/1000ft [Ohms/Km]

MMCX Plug to Push-On SMP Female Right Angle Low Loss Cable Using LMR-100 Coax with HeatShrink, LF Solder



PE3W11752LF/HS

Electrical Specifications

Description	Minimum	Typical	Maximum	Units
Jacket Spark			2,000	Vrms

Specifications by Frequency

Part Number	Length	Description	F1	F2	F3	F4	F5	Units	Weight (lbs)
			Frequency					MHz	
PE3W11752LF/HS	Custom Lengths Available	Insertion Loss (Typ.)	0.064	0.115	0.165	0.24	0.432	dB/ft	
			0.21	0.38	0.55	0.79	1.42	dB/m	
PE3W11752LF/HS-24	24 In	Insertion Loss (Typ.)	0.43	0.53	0.63	0.78	1.17	dB	0.033
PE3W11752LF/HS-36	36 In	Insertion Loss (Typ.)	0.5	0.65	0.8	1.02	1.6	dB	0.042
PE3W11752LF/HS-48	48 In	Insertion Loss (Typ.)	0.56	0.76	0.96	1.26	2.03	dB	0.051
PE3W11752LF/HS-100CM	100 CM	Insertion Loss (Typ.)	0.51	0.68	0.85	1.09	1.72	dB	0.045
PE3W11752LF/HS-200CM	200 CM	Insertion Loss (Typ.)	0.72	1.06	1.39	1.88	3.14	dB	0.075

The insertion loss data for the base model does not include loss due to the connectors. Each length includes insertion loss due to the connectors.

Loss due to Connector 1:	0.1 dB
Loss due to Connector 2:	0.2 dB
Base Weight:	0.024 pounds
Additional Weight per Inch:	0.00075 pounds

Mechanical Specifications

Cable Assembly

Width/Diameter	0.5 in [12.7 mm]
Weight	0.0145 lbs [6.58 g]

Cable

Cable Type	LMR-100A
Impedance	50 Ohms
Inner Conductor Type	Solid
Inner Conductor Material and Plating	Copper Clad Steel
Dielectric Type	PE
Number of Shields	2
Shield Layer 1	Aluminum Tape
Shield Layer 2	Tinned Copper Braid
Jacket Material	PVC, Black
Jacket Diameter	0.11 in [2.79 mm]
One Time Minimum Bend Radius	0.25 in [6.35 mm]
Repeated Minimum Bend Radius	1 in [25.4 mm]
Bending Moment	0.1 lbs-ft [0.14 N-m]
Flat Plate Crush	10 lbs/in [0.18 Kg/mm]
Tensile Strength	15 lbs [6.8 Kg]

MMCX Plug to Push-On SMP Female Right Angle Low Loss Cable Using LMR-100 Coax with HeatShrink, LF Solder



PE3W11752LF/HS

Connectors

Description	Connector 1	Connector 2
Type	MMCX Plug	SMP Female Right Angle
Specification	BS EN 122340	MIL-STD-348A
Impedance	50 Ohms	50 Ohms
Configuration	Straight	Right Angle
Connection Method		Push-On
Contact Material and Plating	Brass, Gold	Beryllium Copper, Gold
Contact Plating Specification	30 µin minimum	30 µin minimum
Dielectric Type	PTFE	Teflon
Outer Conductor Material and Plating	Brass, Gold	Beryllium Copper, Gold
Outer Conductor Plating Specification	3 µin minimum	3 µin minimum
Body Material and Plating	Brass, Gold	Brass, Gold
Body Plating Specification	3 µin minimum	3 µin minimum

Environmental Specifications

Operating Range Temperature -40 to +85 deg C

Compliance Certifications (see [product page](#) for current document)

Plotted and Other Data

Notes:

MMCX Plug to Push-On SMP Female Right Angle Low Loss Cable Using LMR-100 Coax with HeatShrink, LF Solder



PE3W11752LF/HS

Typical Performance Data

How to Order

Part Number Configuration:

PE3W11752LF/HS - xx

uu

Unit of Measure:

cm = Centimeters

<blank> = Inches

Length

Base Number

Example: PE3W11752LF/HS-12 = 12 inches long cable
PE3W11752LF/HS-100cm = 100 cm long cable

MMCX Plug to Push-On SMP Female Right Angle Low Loss Cable Using LMR-100 Coax with HeatShrink, LF Solder from Pasternack Enterprises has same day shipment for domestic and International orders. Our RF, microwave and millimeter wave products maintain a 99.4% availability and are part of the broadest selection in the industry.

Click the following link (or enter part number in "SEARCH" on website) to obtain additional part information including price, inventory and certifications: [MMCX Plug to Push-On SMP Female Right Angle Low Loss Cable Using LMR-100 Coax with HeatShrink, LF Solder PE3W11752LF/HS](https://www.pasternack.com/mmcx-plug-to-push-on-smp-female-right-angle-low-loss-cable-using-lmr-100-coax-with-heatshrink-lf-solder-pe3w11752lf-hs)

URL: <https://www.pasternack.com/mmcx-plug-to-push-on-smp-female-low-loss-cable-using-lmr-100-with-heatshrink-lf-solder-pe3w11752lf-hs-p.aspx>

The information contained within this document is accurate to the best of our knowledge and representative of the part described herein. It may be necessary to make modifications to the part and/or the documentation of the part in order to implement improvements. Pasternack Enterprises reserves the right to make such changes as required. Unless otherwise stated, all specifications are nominal. Pasternack Enterprises does not make any representation or warranty regarding the suitability of the part described herein for any particular purpose, and Pasternack Enterprises does not assume liability arising out of the use of any part or document.

PE3W11752LF/HS CAD Drawing

MMCX Plug to Push-On SMP Female Right Angle Low Loss Cable
Using LMR-100 Coax with HeatShrink, LF Solder

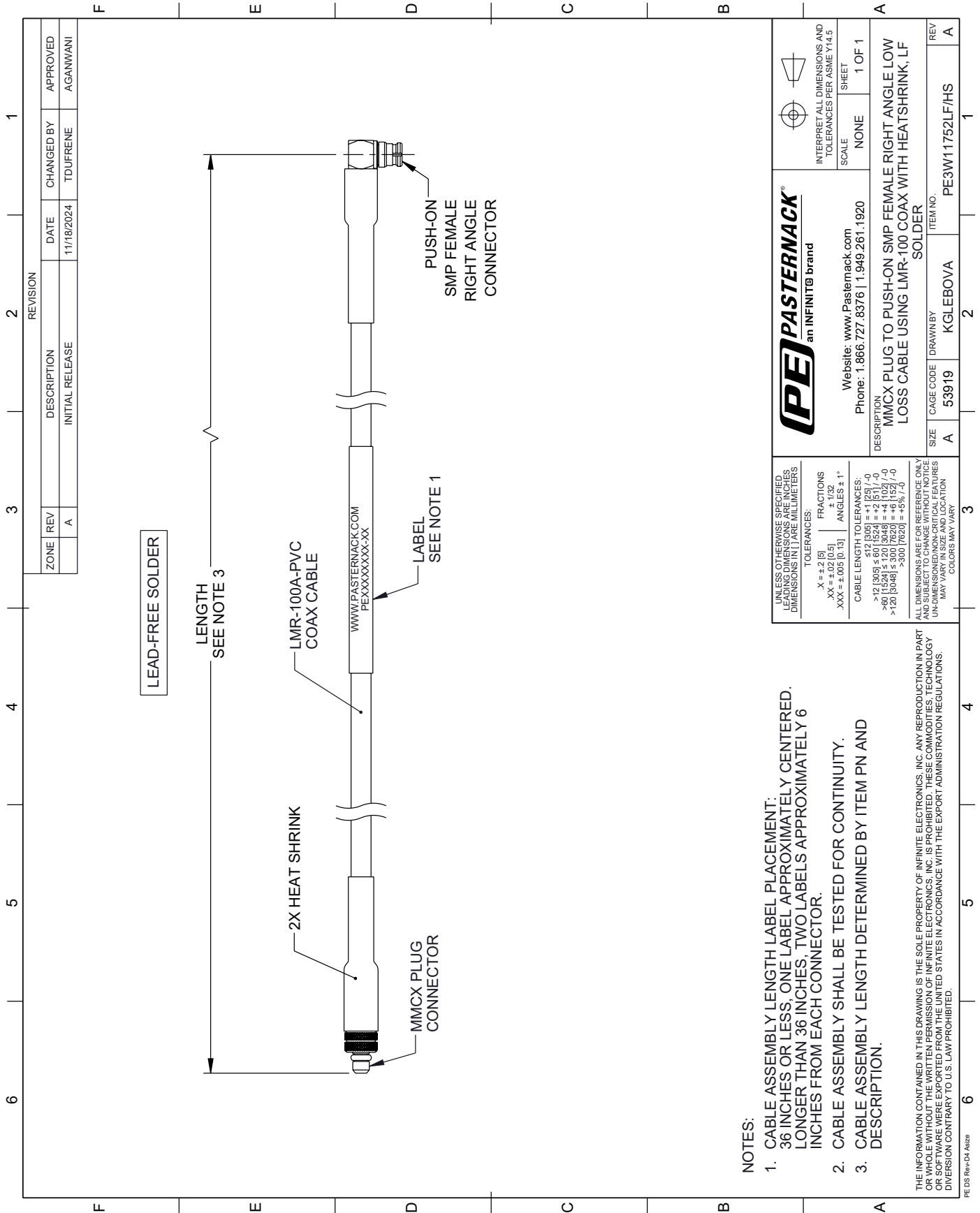

NOTES:

1. CABLE ASSEMBLY LENGTH LABEL PLACEMENT: 36 INCHES OR LESS, ONE LABEL APPROXIMATELY CENTERED. LONGER THAN 36 INCHES, TWO LABELS APPROXIMATELY 6 INCHES FROM EACH CONNECTOR.
2. CABLE ASSEMBLY SHALL BE TESTED FOR CONTINUITY.
3. CABLE ASSEMBLY LENGTH DETERMINED BY ITEM PN AND DESCRIPTION.

ALL DIMENSIONS ARE FOR REFERENCE ONLY. THE INFORMATION CONTAINED IN THIS DRAWING IS THE SOLE PROPERTY OF INFINITE ELECTRONICS, INC. ANY REPRODUCTION IN PART OR WHOLE WITHOUT THE WRITTEN PERMISSION OF INFINITE ELECTRONICS, INC. IS PROHIBITED. THESE COMMODITIES, TECHNOLOGY OR SOFTWARE WERE EXPORTED FROM THE UNITED STATES IN ACCORDANCE WITH THE EXPORT ADMINISTRATION REGULATIONS. DIVERSION CONTRARY TO U.S. LAW PROHIBITED.

UNLESS OTHERWISE SPECIFIED LEADING DIMENSIONS ARE IN INCHES DIMENSIONS IN PARENTHESSES ARE IN MILLIMETERS	
TOLERANCES:	
.X = ±.2 [5]	FRACTIONS ± 1/32
.XX = ±.02 [0.5]	ANGLES ± 1°
.XXX = ±.005 [0.13]	
CABLE LENGTH TOLERANCES:	
>12 [305] ≤ 60 [1524] = +1 [25] / -0	
>60 [1524] ≤ 120 [3048] = +4 [102] / -0	
>120 [3048] ≤ 300 [7620] = +5 [127] / -0	
>300 [7620] = +5 [127] / -0	
ALL DIMENSIONS ARE FOR REFERENCE ONLY. UNDIMENSIONED CRITICAL FEATURES MAY VARY IN SIZE AND LOCATION. COLORS MAY VARY.	

Website: www.Pasternack.com Phone: 1.866.727.8376 1.949.261.1920		SCALE: NONE SHEET: 1 OF 1
DESCRIPTION: MMCX PLUG TO PUSH-ON SMP FEMALE RIGHT ANGLE LOW LOSS CABLE USING LMR-100 COAX WITH HEATSHRINK, LF SOLDER		
SIZE: A	CAGE CODE: 53919	DRAWN BY: KGLEBOVA
ITEM NO.: PE3W11752LF/HS		REV: A