



7/16 DIN Male Right Angle Connector Crimp/Solder Attachment for LMR-195, LMR-195-FR, 0.195 inch, PE-C195, PE-P195

RF Connectors Technical Data Sheet

PE45046

Configuration

- 7/16 DIN Male Connector
- IEC 169-4
- 50 Ohms
- Right Angle Body Geometry
- LMR-195, LMR-195-FR, 0.195 inch, PE-C195, PE-P195 Interface Type
- Crimp/Solder Attachment
- 32 mm Hex

Features

- Max. Operating Frequency 3 GHz
- Excellent VSWR of 1.2:1
- Silver Plated Brass Contact

Applications

- General Purpose Test
- Custom Cable Assemblies

Description

Pasternack's PE45046 7/16 DIN male right angle connector with crimp/solder attachment for LMR-195, LMR-195-FR, 0.195 inch, PE-C195 and PE-P195 is part of our full line of RF components available for same-day shipping. Our 7/16 DIN male connector operates up to a maximum frequency of 3 GHz and offers excellent VSWR of 1.2:1. Its right angle body geometry allows for easier connections in tight spaces.

Our 7/16 DIN male right angle connector PE45046 datasheet specifications and drawing with dimensions are shown below in this PDF. Pasternack's broad catalog of RF, microwave and millimeter wave connectors allows designers to configure and customize their signal connections however they like. Whether the need is to provide an I/O for a board design, or simply create a custom cable assembly configuration, Pasternack has the right connector for the job. Pasternack can also expertly build your custom cable assemblies for you and ship same-day.

Electrical Specifications

Description	Minimum	Typical	Maximum	Units
Frequency Range	DC		3	GHz
VSWR			1.2:1	

Mechanical Specifications

Size	
Length	1.77 in [44.96 mm]
Width/Dia.	1.26 in [32.00 mm]
Height	1.55 in [39.37 mm]
Weight	0.11 lbs [49.9 g]

Click the following link (or enter part number in "SEARCH" on website) to obtain additional part information including price, inventory and certifications: [7/16 DIN Male Right Angle Connector Crimp/Solder Attachment for LMR-195, LMR-195-FR, 0.195 inch, PE-C195, PE-P195 PE45046](#)



7/16 DIN Male Right Angle Connector Crimp/Solder Attachment
for LMR-195, LMR-195-FR, 0.195 inch, PE-C195, PE-P195

RF Connectors Technical Data Sheet

PE45046

Material Specifications

Description	Material	Plating
Contact	Brass	Silver
Insulation	PTFE	
Body	Brass	Tri-Metal
Coupling Nut	Brass	Tri-Metal

Compliance Certifications (see [product page](#) for current document)

Plotted and Other Data

Notes:

7/16 DIN Male Right Angle Connector Crimp/Solder Attachment for LMR-195, LMR-195-FR, 0.195 inch, PE-C195, PE-P195 from Pasternack Enterprises has same day shipment for domestic and International orders. Our RF, microwave and millimeter wave products maintain a 99% availability and are part of the broadest selection in the industry.

Click the following link (or enter part number in "SEARCH" on website) to obtain additional part information including price, inventory and certifications: [7/16 DIN Male Right Angle Connector Crimp/Solder Attachment for LMR-195, LMR-195-FR, 0.195 inch, PE-C195, PE-P195 PE45046](#)

URL: <https://www.pasternack.com/7-16-male-lmr-195-pe-c195-pe-p195-connector-pe45046-p.aspx>

The information contained in this document is accurate to the best of our knowledge and representative of the part described herein. It may be necessary to make modifications to the part and/or the documentation of the part, in order to implement improvements. Pasternack reserves the right to make such changes as required. Unless otherwise stated, all specifications are nominal. Pasternack does not make any representation or warranty regarding the suitability of the part described herein for any particular purpose, and Pasternack does not assume any liability arising out of the use of any part or documentation.

PE45046 CAD Drawing

7/16 DIN Male Right Angle Connector Crimp/Solder Attachment for LMR-195, LMR-195-FR, 0.195 inch, PE-C195, PE-P195

ASSEMBLY PROCEDURES

1. STRIP CABLE AS SHOWN. SLIDE FERRULE OVER CABLE.

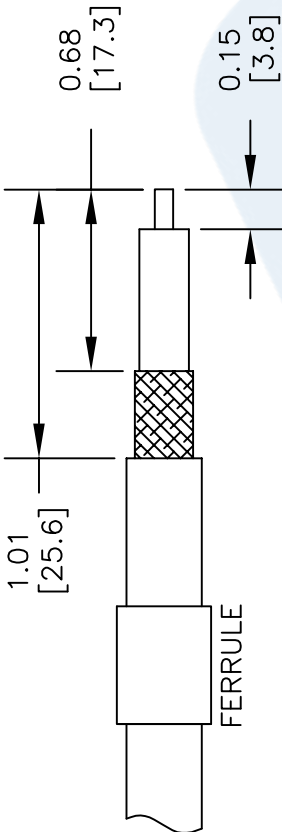

2. FLAIR BRAID AND INSERT THE STRIPPED CABLE INTO BODY AND POSITION THE CENTER CONDUCTOR IN THE SLOT OF THE CENTER PIN.

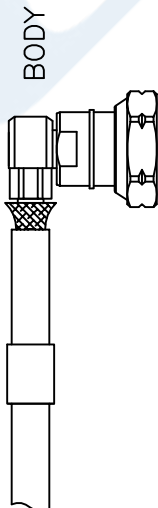

3. SLIDE FERRULE OVER BRAID UP TO THE CONNECTOR BODY AND CRIMP AS CLOSE TO THE CONNECTOR BODY AS POSSIBLE USING A .213" HEX CRIMP TOOL.

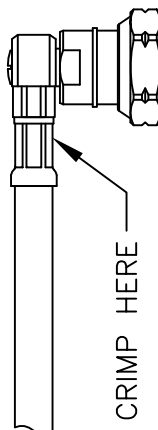

4. SOLDER THE CENTER CONDUCTOR OF THE CABLE TO THE CENTER PIN. TIGHTEN DOWN THE CAP INTO THE REAR APERTURE OF THE BO



CRIMP SIZE REQUIRED

CONTACT: SOLDER
FERRULE: .213" HEX CRIMP TOOL

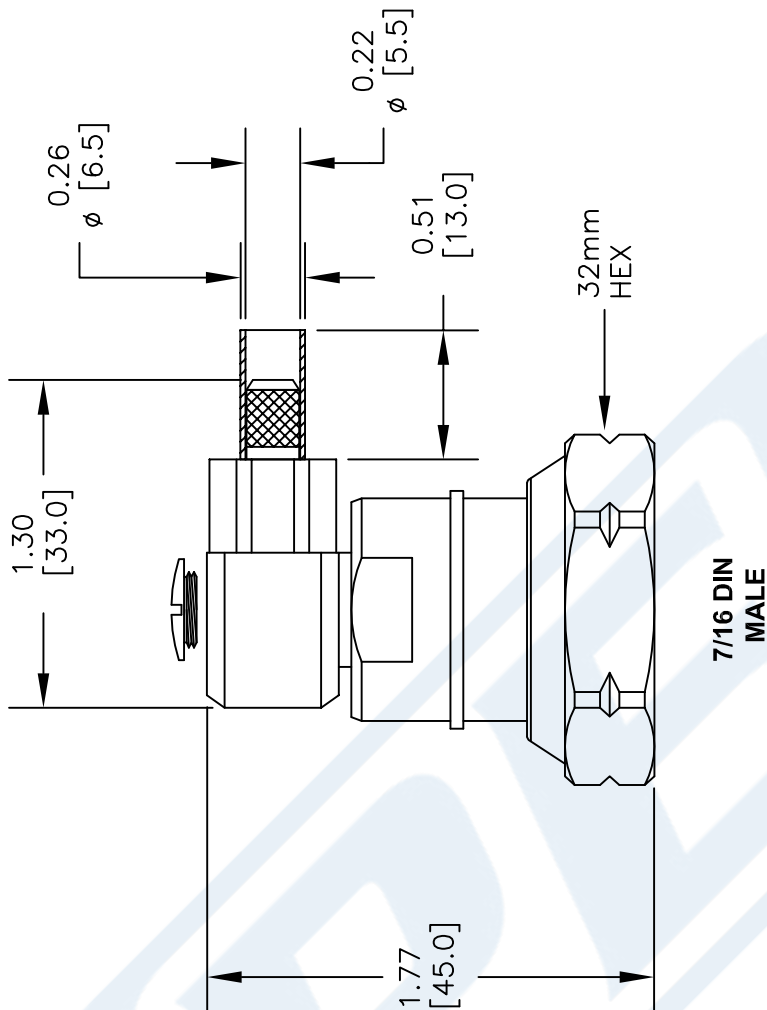

DWG TITLE

PE45046

NOTES:
1. UNLESS OTHERWISE SPECIFIED ALL DIMENSIONS ARE NOMINAL.
2. ALL SPECIFICATIONS ARE SUBJECT TO CHANGE WITHOUT NOTICE AT ANY TIME.
3. DIMENSIONS ARE IN INCHES [mm].

PE PASTERNAK
THE ENGINEER'S RF SOURCE
Pasternack Enterprises, Inc.
P.O. Box 16759 | Irvine | CA | 92623
Phone: (949) 261-1920 | Fax: (949) 261-7451
Website: www.pasternack.com | E-Mail: sales@pasternack.com

FSCM NO. 53919

CAD FILE 100214

SCALE N/A

SIZE A

150