



75 Ohm TNC Male Connector Crimp/Solder Attachment for RG179, RG187, RG316

RF Connectors Technical Data Sheet

PE45687

Configuration

- TNC Male Connector
- 75 Ohms
- Straight Body Geometry
- Connector Interface Types: RG179, RG187, RG316

Features

- Max. Operating Frequency 2 GHz
- Gold Plated Brass Contact
- 50 μ in. minimum contact plating

Applications

- General Purpose Test
- Custom Cable Assemblies

Description

Pasternack's PE45687 75 ohm TNC male connector with crimp/solder attachment for RG179, RG187 and RG316 is part of our full line of RF components available for same-day shipping. Our TNC male connector operates up to a maximum frequency of 2 GHz.

Our 75 ohm TNC male connector PE45687 datasheet specifications and drawing with dimensions are shown below in this PDF. Pasternack's broad catalog of RF, microwave and millimeter wave connectors allows designers to configure and customize their signal connections however they like. Whether the need is to provide an I/O for a board design, or simply create a custom cable assembly configuration, Pasternack has the right connector for the job. Pasternack can also expertly build your custom cable assemblies for you and ship same-day.

Electrical Specifications

Description	Minimum	Typical	Maximum	Units
Frequency Range	DC		2	GHz
Operating Voltage (AC)			500	Vrms
Dielectric Withstanding Voltage (AC)			1,500	Vrms
Insulation Resistance	5,000			MOhms

Mechanical Specifications

Size

Length	1.1 in [27.94 mm]
Width/Dia.	0.128 in [3.25 mm]
Height	0.59 in [14.99 mm]
Weight	0.034 lbs [15.42 g]

Click the following link (or enter part number in "SEARCH" on website) to obtain additional part information including price, inventory and certifications: [75 Ohm TNC Male Connector Crimp/Solder Attachment for RG179, RG187, RG316 PE45687](#)



75 Ohm TNC Male Connector Crimp/Solder Attachment for RG179, RG187, RG316

RF Connectors
Technical Data Sheet

PE45687

Material Specifications

Description	Material	Plating
Contact	Brass	Gold 50µ in. minimum
Body	Brass	Nickel 200µ in. minimum
Coupling Nut	Brass	Nickel 200µ in. minimum

Environmental Specifications

Temperature

Operating Range -65 to +125 deg C

Compliance Certifications (see [product page](#) for current document)

Plotted and Other Data

Notes:

75 Ohm TNC Male Connector Crimp/Solder Attachment for RG179, RG187, RG316 from Pasternack Enterprises has same day shipment for domestic and International orders. Our RF, microwave and millimeter wave products maintain a 99.4% availability and are part of the broadest selection in the industry.

Click the following link (or enter part number in "SEARCH" on website) to obtain additional part information including price, inventory and certifications: [75 Ohm TNC Male Connector Crimp/Solder Attachment for RG179, RG187, RG316 PE45687](#)

URL: <https://www.pasternack.com/75-Ohm-TNC-Male-Connector-Crimp-Solder-Attachment-for-RG179-RG187-RG316-PE45687-p.aspx>

The information contained in this document is accurate to the best of our knowledge and representative of the part described herein. It may be necessary to make modifications to the part and/or the documentation of the part, in order to implement improvements. Pasternack reserves the right to make such changes as required. Unless otherwise stated, all specifications are nominal. Pasternack does not make any representation or warranty regarding the suitability of the part described herein for any particular purpose, and Pasternack does not assume any liability arising out of the use of any part or documentation.

PE45687 CAD Drawing

75 Ohm TNC Male Connector Crimp/Solder Attachment for RG179, RG187, RG316

REVISIONS			
REV.	DESCRIPTION	DATE	APPROVED
B	PCR PE45687 20220523	06/03/2022	SRAUTUS

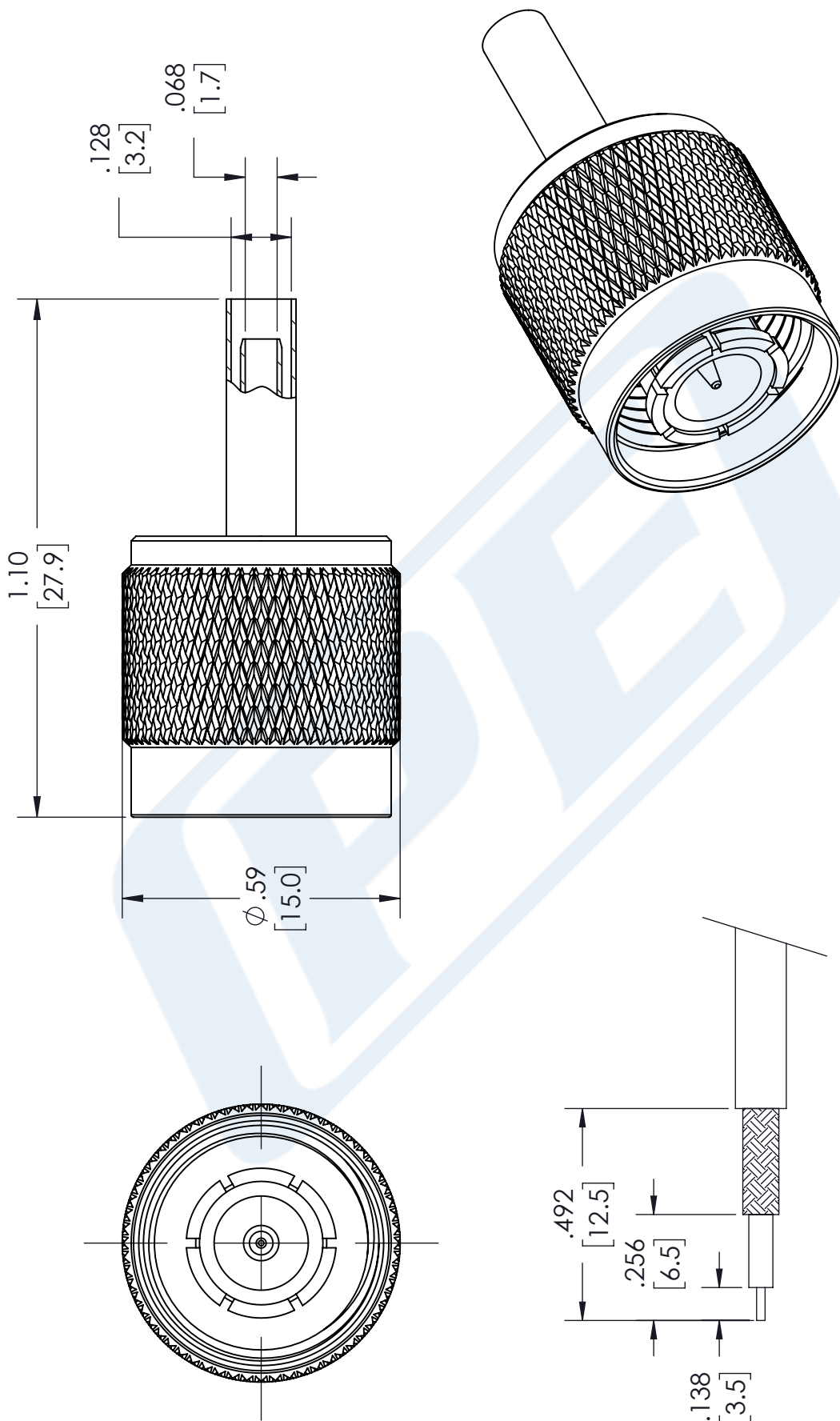

STRIPPING DIMENSIONS

NOTES:

- CABLE ATTACHMENT:
 - OUTER: CRIMP.
 - CONTACT: SOLDER.
- CRIMP SIZE REQUIRED:
 - FERRULE: .128 [3.25] HEX. CRIMP TOOL.

UNLESS OTHERWISE SPECIFIED LEADING DIMENSIONS ARE INCHES DIMENSIONS IN [] ARE MILLIMETERS

TOLERANCES:

.X = ±.2 [5.08] FRACTIONS ± 1/32
 .XX = ±.02 [.51] ANGLES ± 1°
 .XXX = ±.005 [.13]

CABLE LENGTH (L) TOLERANCES:
 L ≤ 12 [305] = +1 [25] / -0
 12 [305] < L ≤ 60 [1524] = +2 [51] / -0
 60 [1524] < L ≤ 120 [3048] = +4 [102] / -0
 120 [3048] < L ≤ 300 [7620] = +6 [152] / -0
 300 [7620] < L = +5% / -0

ALL DIMENSIONS SHOWN ARE FOR REFERENCE ONLY.

THIRD-ANGLE PROJECTION

THE INFORMATION AND DESIGN IN THIS DOCUMENT IS THE PROPERTY OF PASTERNAK CORPORATION ALL RIGHTS RESERVED.

SHEET 1 OF 1

SCALE N/A

REV B

ITEM NO. PE45687

DRAWN BY MVEERAPPAN

CAGE CODE 53919

ITEM NO. PE45687

an INFINITE® brand

PASTERNAK

Pasternack Enterprises, Inc.
 P. O. Box 16759, Irvine, CA 92623.
 Phone: 1.949.261.1920 | 1.866.727.8376
 Fax: 1.949.261.7451
 Website: www.pasternack.com
 E-mail: sales@pasternack.com