



617 to 7125 MHz Wi-Fi 6E Omni Antenna,
3 dBi Gain, N Female Connector White

Antennas Technical Data Sheet

PEANOM1057

Features

- N Type Female Connector
- Vertical Polarization
- Outdoor Rated Omnidirectional Antenna
- 2.4 GHz, 5 GHz, 6 GHz Wi-Fi Bands
- 5 dBi gain
- 100 Watt Max Power

Applications

- Infotainment systems, Routers, Wi-Fi hotspots, HD video transmission, Gateways, Dash cameras, Public transportation
- Connected cars or self-driving cars, Fleet management, Logistics
- Public Safety Networks
- IoT, Industrial IoT, Zigbee, Bluetooth, Wi-Fi

Description

The PEANOM1057 Wi-Fi 6e Omni Antenna from Pasternack's is a high performance omnidirectional antenna designed for the 617 MHz to 7125 MHz bands and is available to ship same day. It is a UV protected, outdoor rated antenna with omnidirectional pattern. The PEANOM1057 is ideally suited for 802.11 protocols including 802.11ax as well as IoT, Zigbee and Bluetooth.

The Pasternack's high performance omni PEANOM1057 is a rugged antenna providing broad coverage, low latency, increased network capacity and 3 dBi gain. This port N Female omnidirectional antenna is suitable for commercial radios and access points in public and private networks that are equipped with N Type connectors.

This Wi-Fi 6e PEANOM1057 omni antenna with N Female connectors, as well as our wide selection of superior quality RF parts, ships same day. Contact our knowledgeable and friendly technical support and sales staff for your answers on antennas or other Pasternack's products.

Configuration

Design	Omni
Application Band	Wi-Fi 6E
Band Type	Dual
Radiation Pattern	Omnidirectional
Polarization	Vertical
Connector Type	N Female
Number of Ports	1

Electrical Specifications

Description	Minimum	Typical	Maximum	Units
Frequency Range	617		7,125	MHz
Input VSWR			2.5:1	
Impedance		50		Ohms
Gain Variation		±0.5		dBi
Input Power			100	Watts

Click the following link (or enter part number in "SEARCH" on website) to obtain additional part information including price, inventory and certifications: [617 to 7125 MHz Wi-Fi 6E Omni Antenna, 3 dBi Gain, N Female Connector White PEANOM1057](#)



617 to 7125 MHz Wi-Fi 6E Omni Antenna,
3 dBi Gain, N Female Connector White

Antennas Technical Data Sheet

PEANOM1057

Specifications by Band

Description	Band 1	Band 2	Band 3	Band 4	Band 5	Units
Range	0.617 to 0.96	1.71 to 7.125				GHz
Gain	2	5				dBi
Horizontal Beam Width	360	360				Degrees
Vertical Beam Width	60	45				Degrees

Mechanical Specifications

Radome Material	UV Resistant ABS
Size	
Overall Length	3.75 in [95.25 mm]
Width	1.6 in [40.64 mm]
Height	1.6 in [40.64 mm]
Weight	0.45 lbs [204.12 g]

Environmental Specifications

Temperature	
Operating Range	-40 to +85 deg C
Humidity	5 to 95

Compliance Certifications (see [product page](#) for current document)

Plotted and Other Data

Notes:

Click the following link (or enter part number in "SEARCH" on website) to obtain additional part information including price, inventory and certifications: [617 to 7125 MHz Wi-Fi 6E Omni Antenna, 3 dBi Gain, N Female Connector White PEANOM1057](#)



617 to 7125 MHz Wi-Fi 6E Omni Antenna,
3 dBi Gain, N Female Connector White

Antennas Technical Data Sheet

PEANOM1057

617 to 7125 MHz Wi-Fi 6E Omni Antenna, 3 dBi Gain, N Female Connector White from Pasternack Enterprises has same day shipment for domestic and International orders. Our RF, microwave and millimeter wave products maintain a 99.4% availability and are part of the broadest selection in the industry.

Click the following link (or enter part number in "SEARCH" on website) to obtain additional part information including price, inventory and certifications: [617 to 7125 MHz Wi-Fi 6E Omni Antenna, 3 dBi Gain, N Female Connector White PEANOM1057](https://www.pasternack.com/617-to-7125-mhz-wi-fi-6e-omni-antenna-3-dbi-gain-n-female-connector-white-peanom1057)

URL: <https://www.pasternack.com/617-to-7125-mhz-wi-fi-6e-omni-antenna-3-dbi-gain-n-female-connector-white-peanom1057-p.aspx>

The information contained in this document is accurate to the best of our knowledge and representative of the part described herein. It may be necessary to make modifications to the part and/or the documentation of the part, in order to implement improvements. Pasternack reserves the right to make such changes as required. Unless otherwise stated, all specifications are nominal. Pasternack does not make any representation or warranty regarding the suitability of the part described herein for any particular purpose, and Pasternack does not assume any liability arising out of the use of any part or documentation.

PEANOM1057 CAD Drawing

617 to 7125 MHz Wi-Fi 6E Omni Antenna, 3 dBi Gain, N Female Connector White

F E D C B A

1

2

3

4

5

6

REVISION		ZONE	REV.	DESCRIPTION	DATE	CHANGED BY	APPROVED BY
		A		INITIAL RELEASE	01/17/2023	PSRINIVAS	KHIETPAS

LABEL PER ILS-100-05
(SEE NOTE 1)

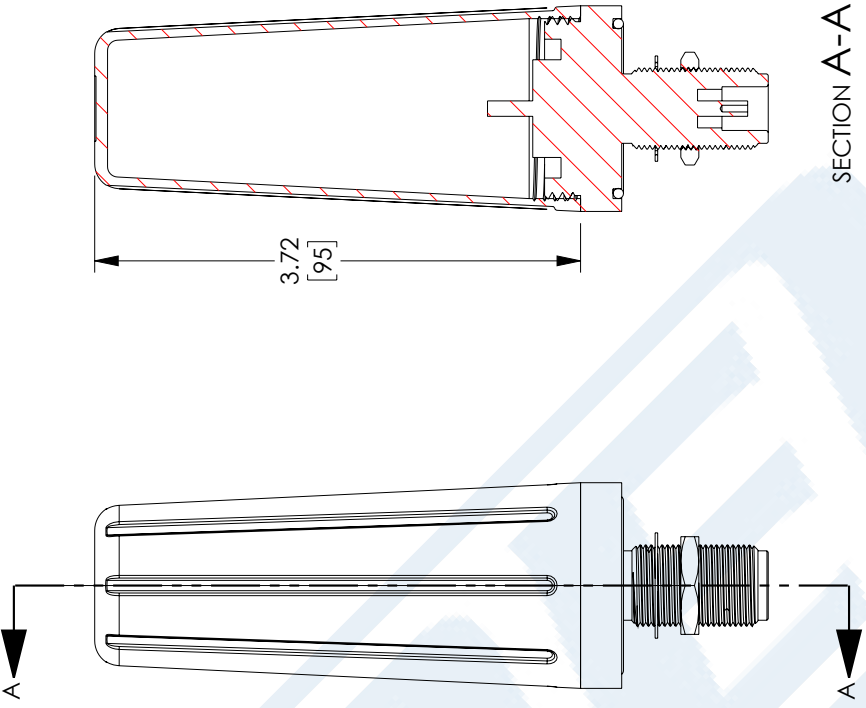
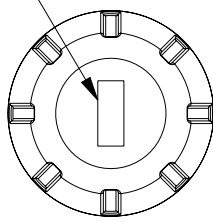

SECTION A-A

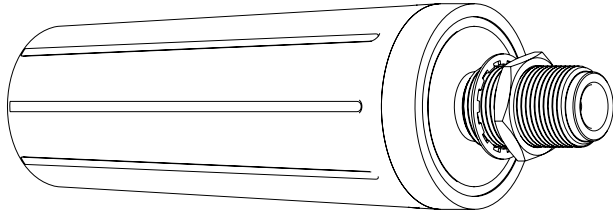
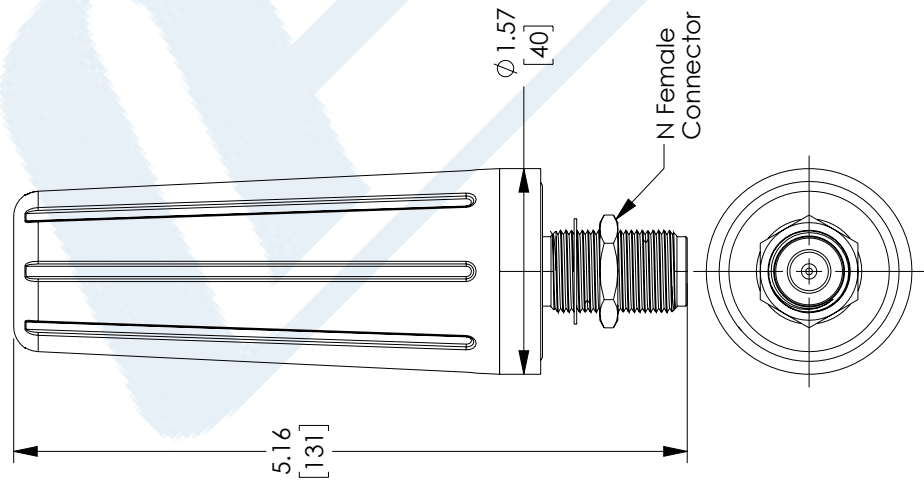

NOTES:

1. LABEL PER ILS-100-05 (FOR INTERNAL USE ONLY).
LABEL LOCATION SHOWN IS FOR REFERENCE ONLY.

REGULATORY COMPLIANCE:

EU RoHS DIRECTIVE (MOST RECENT RELEASED VERSION)

THE INFORMATION CONTAINED IN THIS DRAWING IS THE SOLE PROPERTY OF INFINITE ELECTRONICS, INC. ANY REPRODUCTION IN PART OR WHOLE WITHOUT THE WRITTEN PERMISSION OF INFINITE ELECTRONICS, INC. IS PROHIBITED. THESE COMMODITIES, TECHNOLOGY OR SOFTWARE WERE EXPORTED FROM THE UNITED STATES IN ACCORDANCE WITH THE EXPORT ADMINISTRATION REGULATIONS. DIVERSION CONTRARY TO U.S. LAW PROHIBITED.



Website: www.Pasternack.com
Phone: 1.866.727.8376 | 1.949.261.1920

DESCRIPTION
617-7125MHZ 3DBI OMNI ANTENNA WITH N FEMALE CONNECTOR WHITE

SIZE	CAGE CODE	DRAWN BY	ITEM NO.
A	53919	PSRINIVAS	PEANOM1057

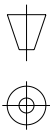

INTERPRET ALL DIMENSIONS AND TOLERANCES PER ASME Y14.5
SCALE NONE
SHEET 1 OF 1

UNLESS OTHERWISE SPECIFIED LEADING DIMENSIONS ARE INCHES DIMENSIONS IN [] ARE MILLIMETERS

TOLERANCES:

X = ±.2 [5] FRACTIONS
XX = ±.02 [.5] ± 1/32
XXX = ±.005 [.13] ANGLES ± 1°
CABLE LENGTH TOLERANCES:
>12 [305] = +1 [25] / -0
>60 [1524] ≤ 60 [1524] = +2 [51] / -0
>120 [3048] ≤ 120 [3048] = +4 [102] / -0
>300 [7620] ≤ 300 [7620] = +6 [152] / -0
>300 [7620] = +5% / -0

ALL DIMENSIONS ARE FOR REFERENCE ONLY AND SUBJECT TO CHANGE WITHOUT NOTICE