



# N Male Right Angle Connector Crimp/Solder Attachment for RG214, RG9, RG225, RG393

## RF Connectors Technical Data Sheet

**PE4483**

### Configuration

- N Male Connector
- MIL-STD-348A
- 50 Ohms
- Right Angle Body Geometry
- Connector Interface Types: RG214, RG9, RG225, RG393

### Features

- Max. Operating Frequency 11 GHz
- Good VSWR of 1.35:1
- Gold Plated Brass Contact
- 30 µin minimum contact plating

### Applications

- General Purpose Test
- Custom Cable Assemblies

### Description

Pasternack's PE4483 type N Right Angle, N, Standard, Connector is part of our full line of RF components available for same-day shipping. Our type N male connector operates up to a maximum frequency of 11 GHz and offers good VSWR of 1.35:1. Its right angle body geometry allows for easier connections in tight spaces.

Our type N male right angle connector PE4483 datasheet specifications and drawing with dimensions are shown below in this PDF. Pasternack's broad catalog of RF, microwave and millimeter wave connectors allows designers to configure and customize their signal connections however they like. Whether the need is to provide an I/O for a board design, or simply create a custom cable assembly configuration, Pasternack has the right connector for the job. Pasternack can also expertly build your custom cable assemblies for you and ship same-day.

### Electrical Specifications

Description	Minimum	Typical	Maximum	Units
Frequency Range	DC		11	GHz
VSWR			1.35:1	
Operating Voltage (AC)			1,000	Vrms
Impedance		50		Ohms
Dielectric Withstanding Voltage (AC)			2,500	Vrms
Inner Conductor DC Resistance			1	mOhms
Outer Conductor DC Resistance			1	mOhms
Insulation Resistance	5,000			MOhms
RF Leakage	90			dB

### Mechanical Specifications

#### Size

Length	1.99 in [50.55 mm]
Width	0.80 in [20.32 mm]
Height	1.29 in [32.77 mm]

Click the following link (or enter part number in "SEARCH" on website) to obtain additional part information including price, inventory and certifications: [N Male Right Angle Connector Crimp/Solder Attachment for RG214, RG9, RG225, RG393 PE4483](#)



N Male Right Angle Connector Crimp/Solder Attachment for RG214, RG9, RG225, RG393

**RF Connectors**  
**Technical Data Sheet**

**PE4483**

Weight 0.14 lbs [61.23 g]  
Mating Cycles 500 Cycles

**Material Specifications**

Description	Material	Plating
Contact	Brass	Gold 30 µin minimum
Insulation	PTFE	
Body	Brass	Nickel 100 µin minimum
Coupling Nut	Brass	Nickel
Crimp Sleeve	Brass	Nickel

**Environmental Specifications**

**Temperature**

Operating Range -65 to 165 deg C  
Vibration MIL-STD-202, Method 204, Condition B  
Temperature Cycle MIL-STD-202, Method 107, Condition B  
Salt Spray MIL-STD-202, Method 101, Condition B

**Compliance Certifications** (see [product page](#) for current document)

**Plotted and Other Data**

Notes:

Click the following link (or enter part number in "SEARCH" on website) to obtain additional part information including price, inventory and certifications: [N Male Right Angle Connector Crimp/Solder Attachment for RG214, RG9, RG225, RG393 PE4483](#)



N Male Right Angle Connector Crimp/Solder  
Attachment for RG214, RG9, RG225, RG393

**RF Connectors**  
**Technical Data Sheet**

**PE4483**

**Assembly Instruction**

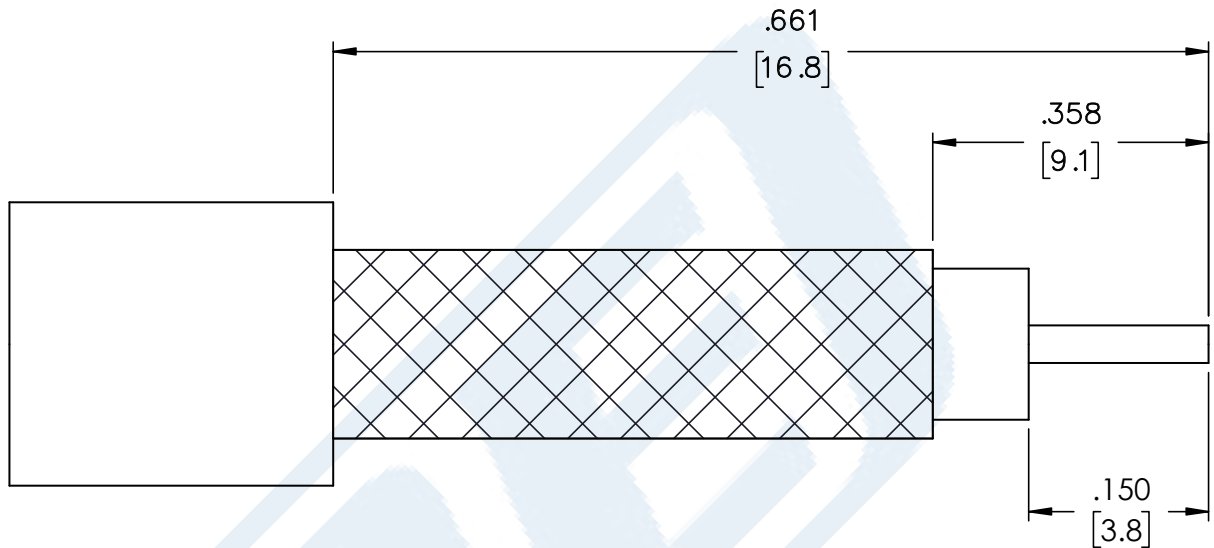

STRIPPING DIMENSIONS

CRIMP SIZE REQUIRED

CONTACT: SOLDER

FERRULE: .429" HEX CRIMP TOOL

Click the following link (or enter part number in "SEARCH" on website) to obtain additional part information including price, inventory and certifications: [N Male Right Angle Connector Crimp/Solder Attachment for RG214, RG9, RG225, RG393 PE4483](#)



## N Male Right Angle Connector Crimp/Solder Attachment for RG214, RG9, RG225, RG393

### RF Connectors Technical Data Sheet

**PE4483**

N Male Right Angle Connector Crimp/Solder Attachment for RG214, RG9, RG225, RG393 from Pasternack Enterprises has same day shipment for domestic and International orders. Our RF, microwave and millimeter wave products maintain a 99.4% availability and are part of the broadest selection in the industry.

Click the following link (or enter part number in "SEARCH" on website) to obtain additional part information including price, inventory and certifications: [N Male Right Angle Connector Crimp/Solder Attachment for RG214, RG9, RG225, RG393 PE4483](https://www.pasternack.com/n-male-standard-rg214-rg9-rg225-rg393-connector-pe4483-p.aspx)

URL: <https://www.pasternack.com/n-male-standard-rg214-rg9-rg225-rg393-connector-pe4483-p.aspx>

The information contained in this document is accurate to the best of our knowledge and representative of the part described herein. It may be necessary to make modifications to the part and/or the documentation of the part, in order to implement improvements. Pasternack reserves the right to make such changes as required. Unless otherwise stated, all specifications are nominal. Pasternack does not make any representation or warranty regarding the suitability of the part described herein for any particular purpose, and Pasternack does not assume any liability arising out of the use of any part or documentation.

# PE4483 CAD Drawing

N Male Right Angle Connector Crimp/Solder Attachment for RG214, RG9, RG225, RG393

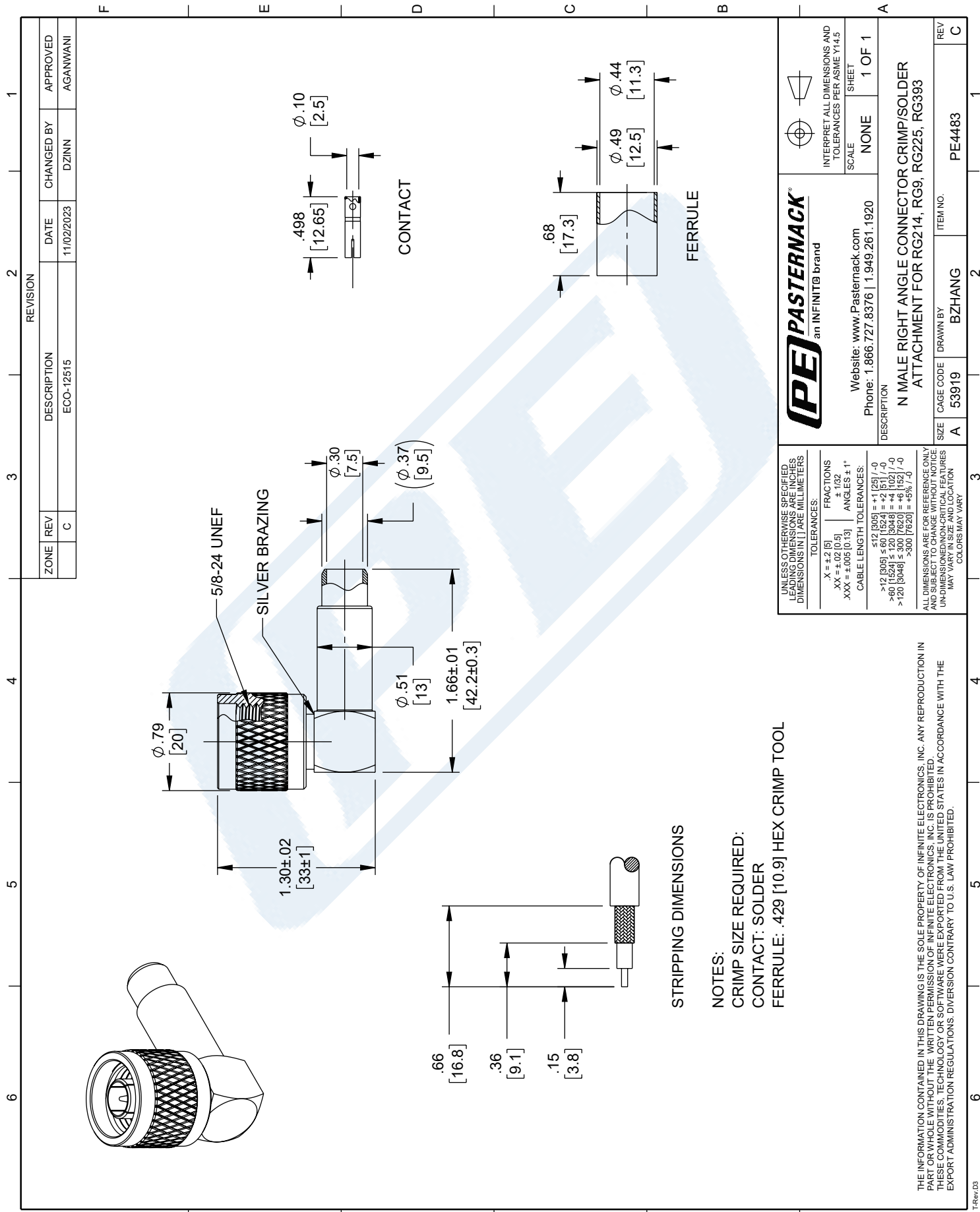

REVISION		DATE	CHANGED BY	APPROVED	
ZONE	REV	DESCRIPTION	ECO-12515	DZINN	AGANWANI
	C				

**PE PASTERNAK**  
an INFINIT® brand

Website: [www.Pasternack.com](http://www.Pasternack.com)  
Phone: 1.866.727.8376 | 1.949.261.1920

INTERPRET ALL DIMENSIONS AND TOLERANCES PER ASME Y14.5  
SCALE: NONE SHEET: 1 OF 1

DESCRIPTION:  
**N MALE RIGHT ANGLE CONNECTOR CRIMP/SOLDER ATTACHMENT FOR RG214, RG9, RG225, RG393**

SIZE: A 53919 | DRAWN BY: BZHANG | ITEM NO.: PE4483 | REV: C

UNLESS OTHERWISE SPECIFIED, ALL DIMENSIONS ARE IN INCHES. DIMENSIONS IN [ ] ARE MILLIMETERS.

TOLERANCES:  
 .X = ±.2 [5]  
 .XX = ±.02 [0.5]  
 .XXX = ±.005 [0.13]  
 FRACTIONS: ± 1/32  
 ANGLES: ± 1°  
 CABLE LENGTH TOLERANCES:  
 ≤12 [305] = +1 [25] / -0  
 >12 [305] ≤60 [1524] = +2 [51] / -0  
 >60 [1524] ≤120 [3048] = +4 [102] / -0  
 >120 [3048] ≤300 [7620] = +6 [152] / -0  
 >300 [7620] = +5% / -0

ALL DIMENSIONS ARE FOR REFERENCE ONLY AND SUBJECT TO CHANGE WITHOUT NOTICE. UNDIMENSIONED NON-CRITICAL FEATURES MAY VARY IN SIZE AND LOCATION. COLORS MAY VARY.

**STRIPPING DIMENSIONS**

**NOTES:**  
 CRIMP SIZE REQUIRED:  
 CONTACT: SOLDER  
 FERRULE: .429 [10.9] HEX CRIMP TOOL

THE INFORMATION CONTAINED IN THIS DRAWING IS THE SOLE PROPERTY OF INFINITE ELECTRONICS, INC. ANY REPRODUCTION IN PART OR WHOLE WITHOUT THE WRITTEN PERMISSION OF INFINITE ELECTRONICS, INC. IS PROHIBITED. THESE COMMODITIES, TECHNOLOGY OR SOFTWARE WERE EXPORTED FROM THE UNITED STATES IN ACCORDANCE WITH THE EXPORT ADMINISTRATION REGULATIONS. DIVERSION CONTRARY TO U.S. LAW PROHIBITED.



# N Male Right Angle Connector Crimp/Solder Attachment for RG214, RG9, RG225, RG393

## RF Connectors Technical Data Sheet

**PE4483**

### Configuration

- N Male Connector
- MIL-STD-348A
- 50 Ohms
- Right Angle Body Geometry
- Connector Interface Types: RG214, RG9, RG225, RG393

### Features

- Max. Operating Frequency 11 GHz
- Good VSWR of 1.35:1
- Gold Plated Brass Contact
- 30 µin minimum contact plating

### Applications

- General Purpose Test
- Custom Cable Assemblies

### Description

Pasternack's PE4483 type N Right Angle, N, Standard, Connector is part of our full line of RF components available for same-day shipping. Our type N male connector operates up to a maximum frequency of 11 GHz and offers good VSWR of 1.35:1. Its right angle body geometry allows for easier connections in tight spaces.

Our type N male right angle connector PE4483 datasheet specifications and drawing with dimensions are shown below in this PDF. Pasternack's broad catalog of RF, microwave and millimeter wave connectors allows designers to configure and customize their signal connections however they like. Whether the need is to provide an I/O for a board design, or simply create a custom cable assembly configuration, Pasternack has the right connector for the job. Pasternack can also expertly build your custom cable assemblies for you and ship same-day.

### Electrical Specifications

Description	Minimum	Typical	Maximum	Units
Frequency Range	DC		11	GHz
VSWR			1.35:1	
Operating Voltage (AC)			1,000	Vrms
Impedance		50		Ohms
Dielectric Withstanding Voltage (AC)			2,500	Vrms
Inner Conductor DC Resistance			1	mOhms
Outer Conductor DC Resistance			1	mOhms
Insulation Resistance	5,000			MOhms
RF Leakage	90			dB

### Mechanical Specifications

#### Size

Length	1.99 in [50.55 mm]
Width	0.80 in [20.32 mm]
Height	1.29 in [32.77 mm]

Click the following link (or enter part number in "SEARCH" on website) to obtain additional part information including price, inventory and certifications: [N Male Right Angle Connector Crimp/Solder Attachment for RG214, RG9, RG225, RG393 PE4483](#)



N Male Right Angle Connector Crimp/Solder Attachment for RG214, RG9, RG225, RG393

**RF Connectors**  
**Technical Data Sheet**

**PE4483**

Weight 0.14 lbs [61.23 g]  
Mating Cycles 500 Cycles

**Material Specifications**

Description	Material	Plating
Contact	Brass	Gold 30 µin minimum
Insulation	PTFE	
Body	Brass	Nickel 100 µin minimum
Coupling Nut	Brass	Nickel
Crimp Sleeve	Brass	Nickel

**Environmental Specifications**

**Temperature**

Operating Range -65 to 165 deg C  
Vibration MIL-STD-202, Method 204, Condition B  
Temperature Cycle MIL-STD-202, Method 107, Condition B  
Salt Spray MIL-STD-202, Method 101, Condition B

**Compliance Certifications** (see [product page](#) for current document)

**Plotted and Other Data**

Notes:

Click the following link (or enter part number in "SEARCH" on website) to obtain additional part information including price, inventory and certifications: [N Male Right Angle Connector Crimp/Solder Attachment for RG214, RG9, RG225, RG393 PE4483](#)



N Male Right Angle Connector Crimp/Solder  
Attachment for RG214, RG9, RG225, RG393

**RF Connectors**  
**Technical Data Sheet**

**PE4483**

**Assembly Instruction**

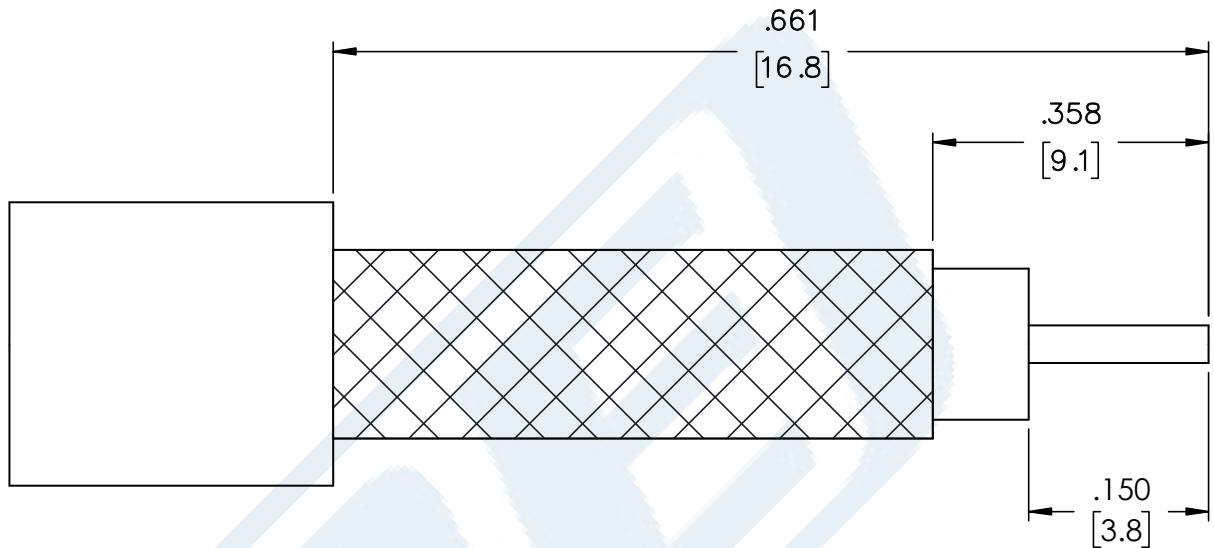

STRIPPING DIMENSIONS

CRIMP SIZE REQUIRED

CONTACT: SOLDER

FERRULE: .429" HEX CRIMP TOOL

Click the following link (or enter part number in "SEARCH" on website) to obtain additional part information including price, inventory and certifications: [N Male Right Angle Connector Crimp/Solder Attachment for RG214, RG9, RG225, RG393 PE4483](#)



## N Male Right Angle Connector Crimp/Solder Attachment for RG214, RG9, RG225, RG393

### RF Connectors Technical Data Sheet

**PE4483**

N Male Right Angle Connector Crimp/Solder Attachment for RG214, RG9, RG225, RG393 from Pasternack Enterprises has same day shipment for domestic and International orders. Our RF, microwave and millimeter wave products maintain a 99.4% availability and are part of the broadest selection in the industry.

Click the following link (or enter part number in "SEARCH" on website) to obtain additional part information including price, inventory and certifications: [N Male Right Angle Connector Crimp/Solder Attachment for RG214, RG9, RG225, RG393 PE4483](https://www.pasternack.com/n-male-standard-rg214-rg9-rg225-rg393-connector-pe4483-p.aspx)

URL: <https://www.pasternack.com/n-male-standard-rg214-rg9-rg225-rg393-connector-pe4483-p.aspx>

The information contained in this document is accurate to the best of our knowledge and representative of the part described herein. It may be necessary to make modifications to the part and/or the documentation of the part, in order to implement improvements. Pasternack reserves the right to make such changes as required. Unless otherwise stated, all specifications are nominal. Pasternack does not make any representation or warranty regarding the suitability of the part described herein for any particular purpose, and Pasternack does not assume any liability arising out of the use of any part or documentation.

# PE4483 CAD Drawing

N Male Right Angle Connector Crimp/Solder Attachment for RG214, RG9, RG225, RG393

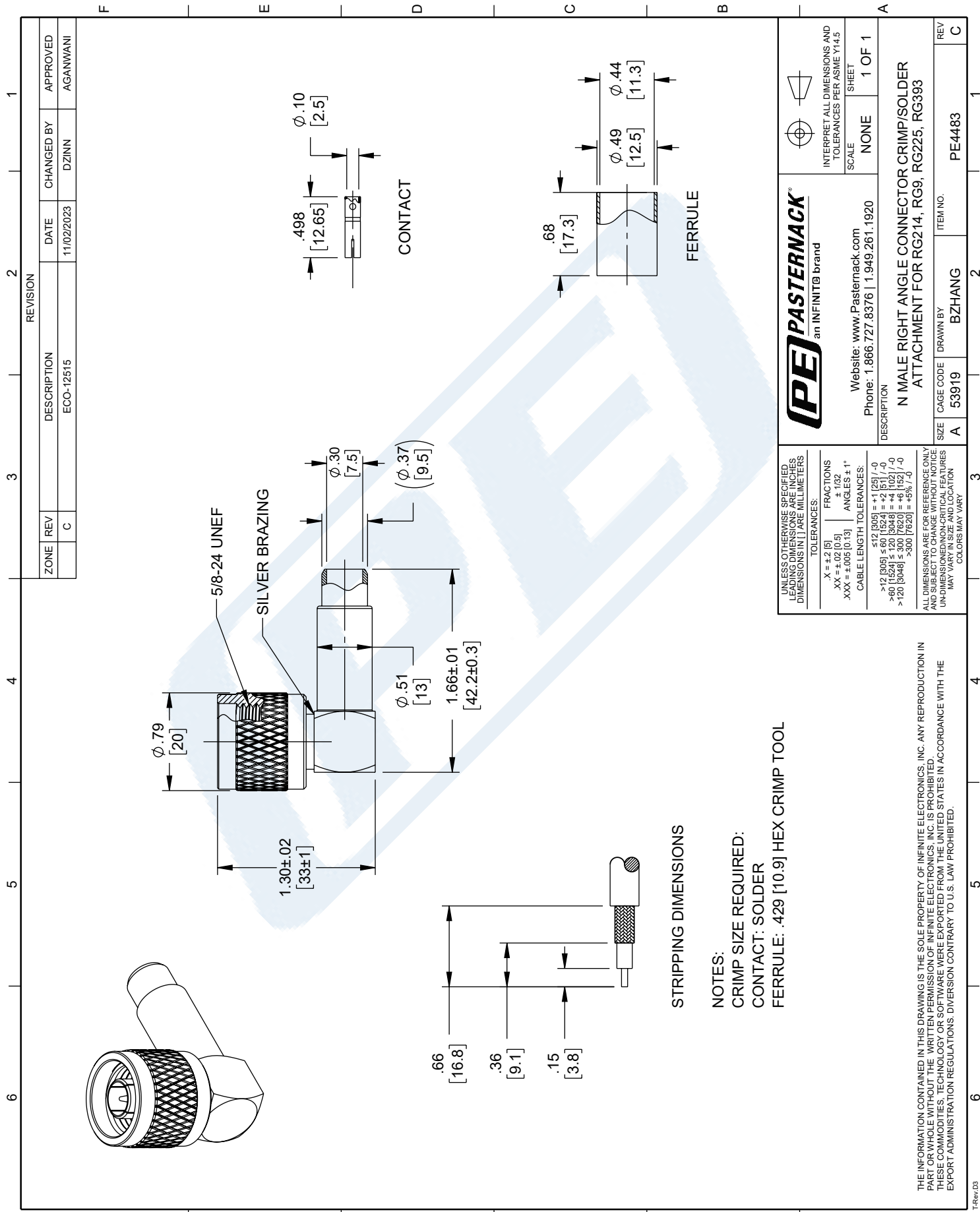

ZONE		REVISION		DATE		APPROVED	
C		ECO-12515		11/02/2023	DZINN		AGANWANI

ZONE	REV	DESCRIPTION	DATE	CHANGED BY	APPROVED
C		ECO-12515	11/02/2023	DZINN	AGANWANI

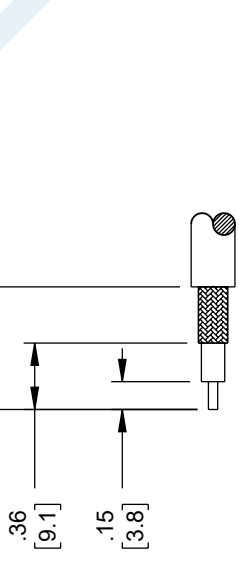
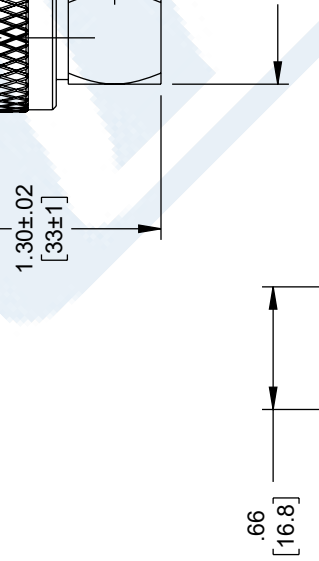
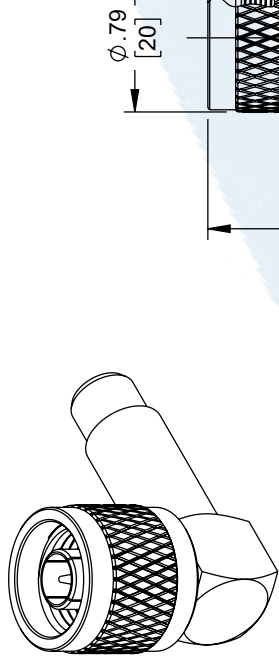

STRIPPING DIMENSIONS

NOTES:  
 CRIMP SIZE REQUIRED:  
 CONTACT: SOLDER  
 FERRULE: .429 [10.9] HEX CRIMP TOOL

UNLESS OTHERWISE SPECIFIED, DIMENSIONS ARE IN INCHES. DIMENSIONS IN [ ] ARE MILLIMETERS.

TOLERANCES:

.X = ±.2 [5]  
 .XX = ±.02 [0.5]  
 .XXX = ±.005 [0.13]

FRACTIONS  
 ± 1/32  
 ANGLES ± 1°

CABLE LENGTH TOLERANCES:

≤12 [305] = +1 [25] / -0  
 >12 [305] ≤60 [1524] = +2 [51] / -0  
 >60 [1524] ≤120 [3048] = +4 [102] / -0  
 >120 [3048] ≤300 [7620] = +6 [152] / -0  
 >300 [7620] = +5% / -0

ALL DIMENSIONS ARE FOR REFERENCE ONLY AND SUBJECT TO CHANGE WITHOUT NOTICE UNLESS INDICATED OTHERWISE. DIMENSIONS MAY VARY BY LOCATION AND COLOR MAY VARY.

**PE PASTERNAK**  
 an INFINIT® brand

Website: [www.Pasternack.com](http://www.Pasternack.com)  
 Phone: 1.866.727.8376 | 1.949.261.1920

INTERPRET ALL DIMENSIONS AND TOLERANCES PER ASME Y14.5

SCALE: NONE  
 SHEET: 1 OF 1

DESCRIPTION:  
 N MALE RIGHT ANGLE CONNECTOR CRIMP/SOLDER ATTACHMENT FOR RG214, RG9, RG225, RG393

SIZE: A 53919  
 DRAWN BY: BZHANG  
 ITEM NO.: PE4483  
 REV: C



## Flexible RG393 Coax Cable Double Shielded with Tan FEP Jacket

### RF Cables Technical Data Sheet

RG393/U

#### Configuration

- Flexible Cable
- 2 Shield(s)

#### Features

- 50 Ohm Impedance
- Stranded Silver Plated Copper center conductor
- PTFE dielectric
- Double Silver Plated Copper Braid
- FEP Jacket Material 0.390 in diameter

#### Electrical Specifications

Description	Minimum	Typical	Maximum	Units
Frequency Range	DC		10	GHz
Impedance		50		Ohms
Velocity of Propagation		69.5		%
Nominal Capacitance		29.4 [96.46]		pF/ft [pF/m]

#### Performance by Frequency Band

Description	F1	F2	F3	F4	F5	Units
Frequency	0.01	0.1	1	5	10	GHz
Attenuation, Typ	0.6	2.1	7.5	21	35	dB/100ft
	1.97	6.89	24.61	68.9	114.83	dB/100m
Input Power (CW), Max	25,000	6,300	1,700	620	350	Watts

#### Mechanical Specifications

Diameter	0.39 in [9.91 mm]
Weight	0.157 lbs/ft [0.23 Kg/m]
Min. Bend Radius (Repeated)	3.9 in [99.06 mm]

#### Construction Specifications

Description	Material and Plating	Diameter
Inner Conductor	Copper, Silver7	0.094 in 2.39 mm
Conductor Type	Stranded	

Click the following link (or enter part number in "SEARCH" on website) to obtain additional part information including price, inventory and certifications: [Flexible RG393 Coax Cable Double Shielded with Tan FEP Jacket RG393/U](#)



## Flexible RG393 Coax Cable Double Shielded with Tan FEP Jacket

### RF Cables Technical Data Sheet

RG393/U

Dielectric	PTFE	0.285 in 7.24 mm
First Shield	Silver Plated Copper Braid 90% coverage	0.313 in 7.95 mm
Second Shield	Silver Plated Copper Braid 90% coverage	0.341 in 8.66 mm
Jacket	FEP, Tan	0.39 in [9.91 mm]

#### Environmental Specifications

##### Temperature

Operating Range

-55 to +200 deg C

**Compliance Certifications** (see [product page](#) for current document)

#### Plotted and Other Data

Notes:

Flexible RG393 Coax Cable Double Shielded with Tan FEP Jacket from Pasternack Enterprises has same day shipment for domestic and International orders. Our RF, microwave and millimeter wave products maintain a 99.4% availability and are part of the broadest selection in the industry.

Click the following link (or enter part number in "SEARCH" on website) to obtain additional part information including price, inventory and certifications: [Flexible RG393 Coax Cable Double Shielded with Tan FEP Jacket RG393/U](#)

URL: <https://www.pasternack.com/flexible-rg393u-fep-jacket-silver-plated-copper-braid-over-silver-plated-copper-braid-outer-conductor-double-shielded-rg393-u-p.aspx>

The information contained in this document is accurate to the best of our knowledge and representative of the part described herein. It may be necessary to make modifications to the part and/or the documentation of the part, in order to implement improvements. Pasternack reserves the right to make such changes as required. Unless otherwise stated, all specifications are nominal. Pasternack does not make any representation or warranty regarding the suitability of the part described herein for any particular purpose, and Pasternack does not assume any liability arising out of the use of any part or documentation.

# RG393/U CAD Drawing

Flexible RG393 Coax Cable Double Shielded with Tan FEP Jacket

REVISIONS			
REV.	DESCRIPTION	DATE	APPROVED
A	PCR RG393/U	1/8/2020	SELLIS

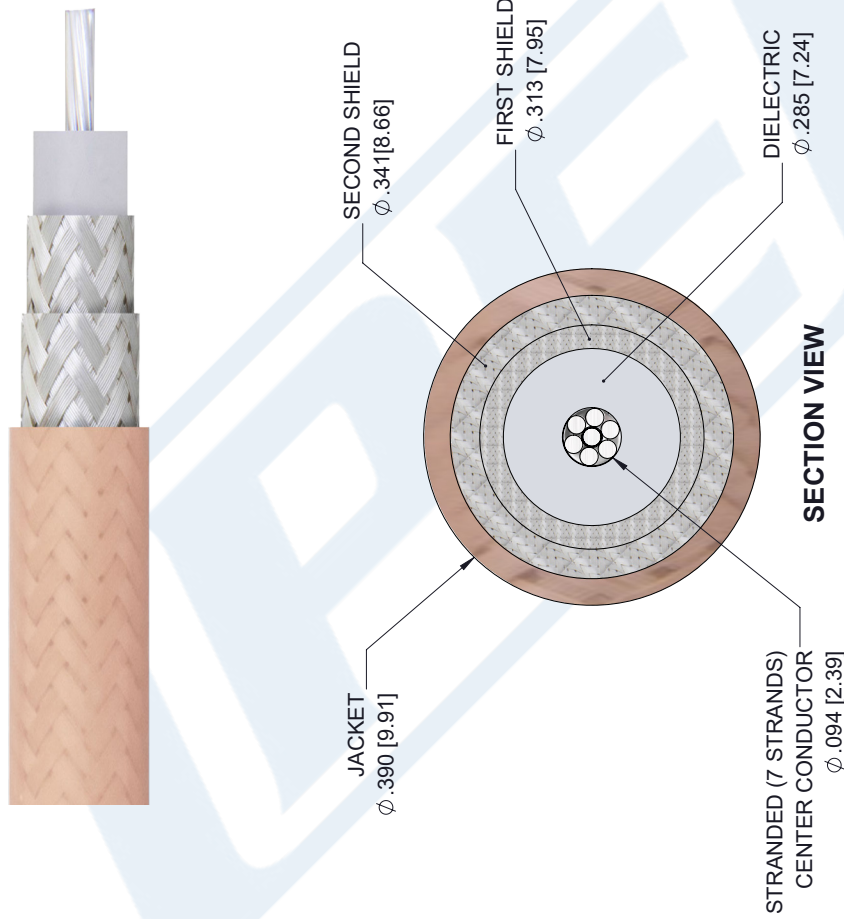

UNLESS OTHERWISE SPECIFIED LEADING DIMENSIONS ARE INCHES DIMENSIONS IN [ ] ARE MILLIMETERS

**TOLERANCES:**

.X = ±.2	[5.08]	FRACTIONS
.XX = ±.02	[.51]	± 1/32
.XXX = ±.005	[.13]	ANGLES ± 1°

**CABLE LENGTH (L) TOLERANCES:**

L ≤ 12	[305]	= +1 [25] / -0
12 [305] < L ≤ 60	[1524]	= +2 [51] / -0
60 [1524] < L ≤ 120	[3048]	= +4 [102] / -0
120 [3048] < L ≤ 300	[7620]	= +6 [152] / -0
300 [7620] < L	= +5%L / -0	

ALL DIMENSIONS SHOWN ARE FOR REFERENCE ONLY.

**PE PASTERNAK**  
an INFINIT brand

Pasternack Enterprises, Inc.  
P.O. Box 16759, Irvine, CA 92623.  
Phone: 1.949.261.1920 | 1.866.727.8376  
Fax: 1.949.261.7451  
Website: www.pasternack.com  
E-mail: sales@pasternack.com

THIRD-ANGLE PROJECTION

THE INFORMATION AND DESIGN IN THIS DOCUMENT IS THE PROPERTY OF PASTERNAK CORPORATION ALL RIGHTS RESERVED.

SHEET 1 OF 1  
SCALE N/A

SIZE [CAGE CODE] DRAWN BY K.DANG  
ITEM NO. RG393/U  
REV A