



SMA Male to TNC Male Low Loss Cable Using LMR-240 Coax with Times Microwave Components

TECHNICAL DATA SHEET

PE3C1981

Configuration

- Connector 1: SMA Male
- Connector 2: TNC Male
- Cable Type: LMR-240
- Coax Flex Type: Flexible

Features

- Max Frequency 5.8 GHz
- Shielding Effectivity > 90 dB
- 84% Phase Velocity
- Double Shielded
- PE Jacket

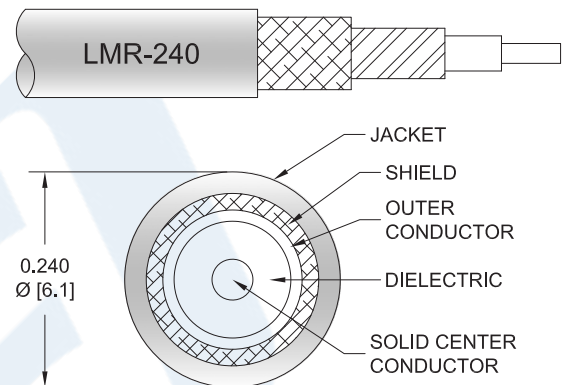

Applications

- General Purpose
- Laboratory Use

Description

Pasternack's PE3C1981 SMA male to TNC male cable using LMR-240 coax is part of our full line of RF components available for same-day shipping. Pasternack's flexible RF cable assemblies are ideal for applications where tight bends and flexure are required. This Pasternack SMA to TNC cable assembly has a male to male gender configuration with 50 ohm flexible LMR-240 coax. The PE3C1981 SMA male to TNC male cable assembly operates to 5.8 GHz. The double shielding of this Pasternack cable assembly provides excellent shielding effectiveness of better than 90 dB.

Custom versions of most RF cable assemblies can be built and shipped same day. Custom cable assembly lengths can be obtained by specifying the desired length on the web site at time of order or by contacting a sales representative. Other available RF cable assembly value added services include connector orientation or clocking, heat shrink booting and custom labeling. RF testing can also be performed to document the electrical performance of your cable assembly.

Click the following link (or enter part number in "SEARCH" on website) to obtain additional part information including price, inventory and certifications: [SMA Male to TNC Male Low Loss Cable Using LMR-240 Coax with Times Microwave Components PE3C1981](#)



SMA Male to TNC Male Low Loss Cable Using LMR-240 Coax with Times Microwave Components

TECHNICAL DATA SHEET

PE3C1981

Electrical Specifications

Description	Minimum	Typical	Maximum	Units
Frequency Range	DC		5.8	GHz
VSWR			1.4:1	
Velocity of Propagation		84		%
RF Shielding	90			dB
Group Delay		1.21 [3.97]		ns/ft [ns/m]
Capacitance		24.2 [79.4]		pF/ft [pF/m]
Inductance		0.06 [0.2]		uH/ft [uH/m]
DC Resistance Inner Conductor		3.2 [10.5]		Ω /1000ft [Ω /Km]
DC Resistance Outer Conductor		3.89 [12.76]		Ω /1000ft [Ω /Km]
Jacket Spark			5,000	Vrms

Specifications by Frequency

Part Number	Length	Description	F1	F2	F3	F4	F5	Units	Weight (lbs)
		Frequency	250	500	1000	2500	5800	MHz	
PE3C1981	Custom Lengths Available	Insertion Loss (Typ.)	0.04	0.06	0.08	0.12	0.2	dB/ft	
			0.13	0.19	0.26	0.4	0.66	dB/m	
PE3C1981-12	12 inch	Insertion Loss (Typ.)	0.44	0.46	0.48	0.52	0.6	dB	0.047
PE3C1981-24	24 inch	Insertion Loss (Typ.)	0.48	0.51	0.56	0.64	0.8	dB	0.05
PE3C1981-36	36 inch	Insertion Loss (Typ.)	0.52	0.57	0.64	0.76	1	dB	0.1
PE3C1981-48	48 inch	Insertion Loss (Typ.)	0.56	0.62	0.72	0.88	1.2	dB	0.12
PE3C1981-60	60 inch	Insertion Loss (Typ.)	0.6	0.68	0.8	1	1.4	dB	0.14

The insertion loss data for the base model does not include loss due to the connectors. Each length includes insertion loss due to the connectors.

Loss due to Connector 1:	0.1 dB
Loss due to Connector 2:	0.3 dB
Base Weight:	0.047 pounds
Additional Weight per Inch:	0.00184 pounds

Mechanical Specifications

Cable Assembly

Weight 0.105 lbs [47.63 g]

Click the following link (or enter part number in "SEARCH" on website) to obtain additional part information including price, inventory and certifications: [SMA Male to TNC Male Low Loss Cable Using LMR-240 Coax with Times Microwave Components PE3C1981](#)



SMA Male to TNC Male Low Loss Cable Using LMR-240 Coax with Times Microwave Components

TECHNICAL DATA SHEET

PE3C1981

Cable

Cable Type	LMR-240
Impedance	50 Ohms
Inner Conductor Type	Solid
Inner Conductor Material and Plating	Copper
Dielectric Type	PE (F)
Number of Shields	2
Shield Layer 1	Aluminum Tape
Shield Layer 2	Tinned Copper Braid
Jacket Material	PE, Black
Jacket Diameter	0.24 in [6.1 mm]
One Time Minimum Bend Radius	0.75 in [19.05 mm]
Repeated Minimum Bend Radius	2.5 in [63.5 mm]
Bending Moment	0.25 lbs-ft [0.34 N-m]
Flat Plate Crush	20 lbs/in [0.36 Kg/mm]
Tensile Strength	80 lbs [36.29 Kg]

Connectors

Description	Connector 1	Connector 2
Type	SMA Male Threaded	TNC Male Threaded
Specification	MIL-STD-348	
Impedance	50 Ohms	50 Ohms
Contact Material and Plating	Beryllium Copper, Gold	Brass, Gold
Contact Plating Specification	ASTM B488	
Dielectric Type	Teflon	Teflon
Body Material and Plating	Passivated Stainless Steel	Brass, Tri-Metal
Body Plating Specification	SAE-AMS-2700	
Coupling Nut Material and Plating	Passivated Stainless Steel	Brass, Tri-Metal
Coupling Nut Plating Specification	SAE-AMS-2700	

Compliance Certifications (see [product page](#) for current document)

Plotted and Other Data

Notes:

Click the following link (or enter part number in "SEARCH" on website) to obtain additional part information including price, inventory and certifications: [SMA Male to TNC Male Low Loss Cable Using LMR-240 Coax with Times Microwave Components PE3C1981](#)



SMA Male to TNC Male Low Loss Cable Using LMR-240 Coax with Times Microwave Components

TECHNICAL DATA SHEET

PE3C1981

How to Order

Part Number Configuration:

PE3C1981

- **xx**

uu

Unit of Measure:
cm = Centimeters
<blank> = Inches
Length
Base Number

Example: PE3C1981-12 = 12 inches long cable
PE3C1981-100cm = 100 cm long cable

SMA Male to TNC Male Low Loss Cable Using LMR-240 Coax with Times Microwave Components from Pasternack Enterprises has same day shipment for domestic and International orders. Our RF, microwave and millimeter wave products maintain a 99.4% availability and are part of the broadest selection in the industry.

Click the following link (or enter part number in "SEARCH" on website) to obtain additional part information including price, inventory and certifications: [SMA Male to TNC Male Low Loss Cable Using LMR-240 Coax with Times Microwave Components PE3C1981](#)

URL: <https://www.pasternack.com/sma-male-to-tnc-male-low-loss-cable-using-lmr-240-pe3c1981-p.aspx>

The information contained in this document is accurate to the best of our knowledge and representative of the part described herein. It may be necessary to make modifications to the part and/or the documentation of the part, in order to implement improvements. Pasternack reserves the right to make such changes as required. Unless otherwise stated, all specifications are nominal. Pasternack does not make any representation or warranty regarding the suitability of the part described herein for any particular purpose, and Pasternack does not assume any liability arising out of the use of any part or documentation.

PE3C1981 CAD Drawing

SMA Male to TNC Male Low Loss Cable Using LMR-240 Coax with Times Microwave Components

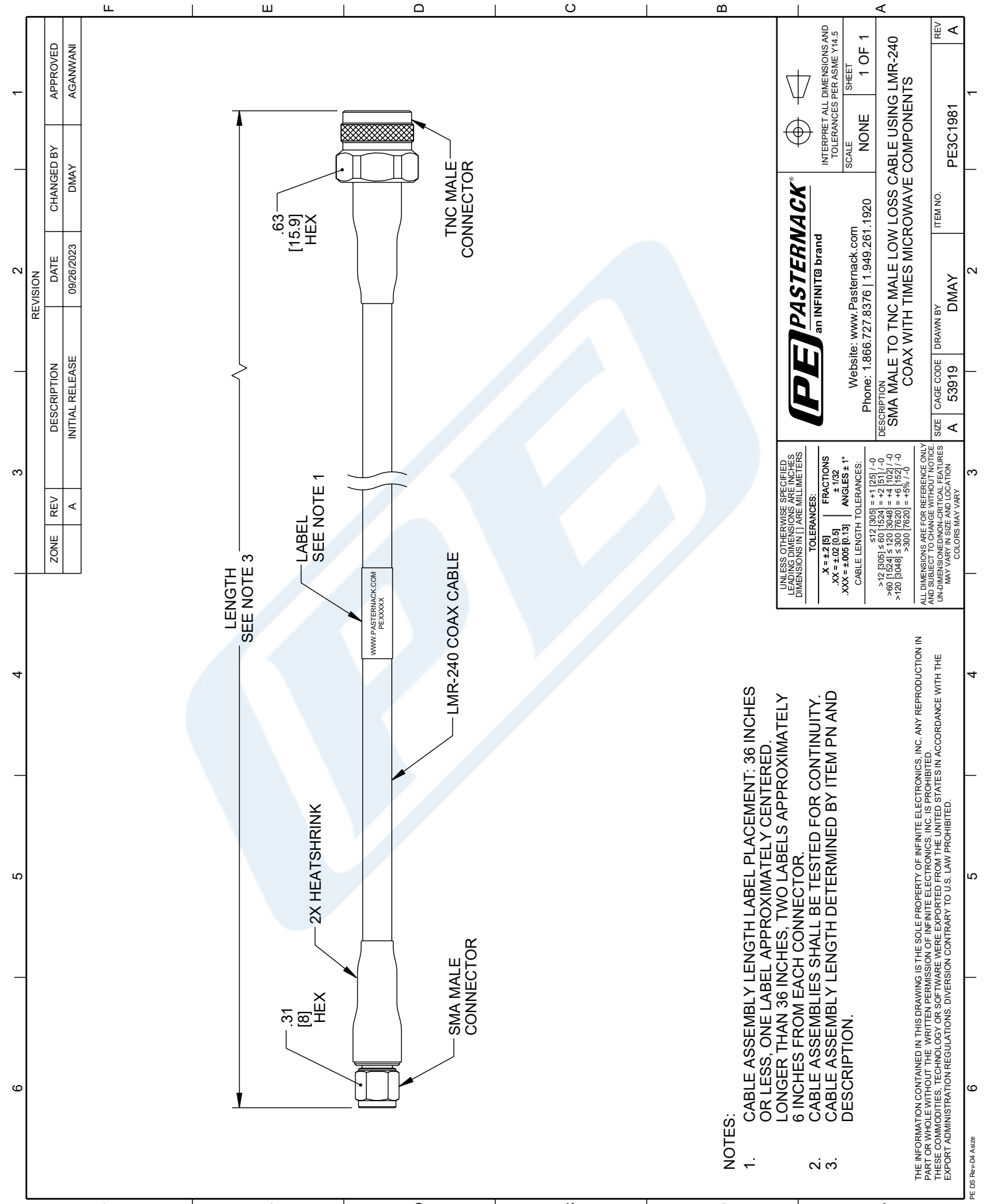

LENGTH
SEE NOTE 3

.63
[15.9]
HEX

TNC MALE
CONNECTOR

LABEL
SEE NOTE 1

WWW.PASTERNAK.COM
PEXXXX

LMR-240 COAX CABLE

2X HEATSHRINK

.31
[8]
HEX

SMA MALE
CONNECTOR

NOTES:

1. CABLE ASSEMBLY LENGTH LABEL PLACEMENT: 36 INCHES OR LESS, ONE LABEL APPROXIMATELY CENTERED. LONGER THAN 36 INCHES, TWO LABELS APPROXIMATELY 6 INCHES FROM EACH CONNECTOR.
2. CABLE ASSEMBLIES SHALL BE TESTED FOR CONTINUITY.
3. CABLE ASSEMBLY LENGTH DETERMINED BY ITEM PN AND DESCRIPTION.

THE INFORMATION CONTAINED IN THIS DRAWING IS THE SOLE PROPERTY OF INFINITE ELECTRONICS, INC. ANY REPRODUCTION IN PART OR WHOLE WITHOUT THE WRITTEN PERMISSION OF INFINITE ELECTRONICS, INC. IS PROHIBITED. THESE COMMODITIES, TECHNOLOGY OR SOFTWARE WERE EXPORTED FROM THE UNITED STATES IN ACCORDANCE WITH THE EXPORT ADMINISTRATION REGULATIONS. DIVERSION CONTRARY TO U.S. LAW PROHIBITED.

ZONE	REV	DESCRIPTION	DATE	CHANGED BY	APPROVED
	A	INITIAL RELEASE	09/26/2023	DMAY	AGANWANI



Website: www.Pasternack.com
Phone: 1.866.727.8376 | 1.949.261.1920

DESCRIPTION:
SMA MALE TO TNC MALE LOW LOSS CABLE USING LMR-240
COAX WITH TIMES MICROWAVE COMPONENTS

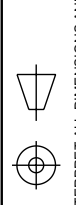

INTERPRET ALL DIMENSIONS AND TOLERANCES PER ASME Y14.5
SCALE NONE
SHEET 1 OF 1

UNLESS OTHERWISE SPECIFIED, LEADING DIMENSIONS ARE IN INCHES, DIMENSIONS IN [] ARE IN MILLIMETERS

TOLERANCES:	FRACTIONS
.X = ±.02 [0.5]	± .132
.XX = ±.005 [0.13]	ANGLES ± 1°

CABLE LENGTH TOLERANCES:

<12 [305]	± .1 [2.5] / -0
>12 [305] ≤ 60 [1524]	± .2 [5.1] / -0
>60 [1524] ≤ 120 [3048]	± .4 [10.2] / -0
>120 [3048] ≤ 300 [7620]	± .6 [15.2] / -0
>300 [7620]	± .8 [20.3] / -0

ALL DIMENSIONS ARE FOR REFERENCE ONLY. ALL DIMENSIONS ARE TO UNLESS OTHERWISE SPECIFIED. UNDIMENSIONED NON-CRITICAL FEATURES MAY VARY IN SIZE AND LOCATION. COLORS MAY VARY.

SIZE	CAGE CODE	DRAWN BY	ITEM NO.	REV
A	53919	DMAY	PE3C1981	A