



## Clamped N Male to TNC Male Right Angle Low Loss Cable Using LMR-400 Coax with Times Microwave Components

### TECHNICAL DATA SHEET

PE3C2485

#### Configuration

- Connector 1: N Male
- Connector 2: TNC Male Right Angle
- Cable Type: LMR-400
- Coax Flex Type: Flexible

#### Features

- Max Frequency 5.8 GHz
- Shielding Effectivity > 90 dB
- 85% Phase Velocity
- Double Shielded
- PE Jacket

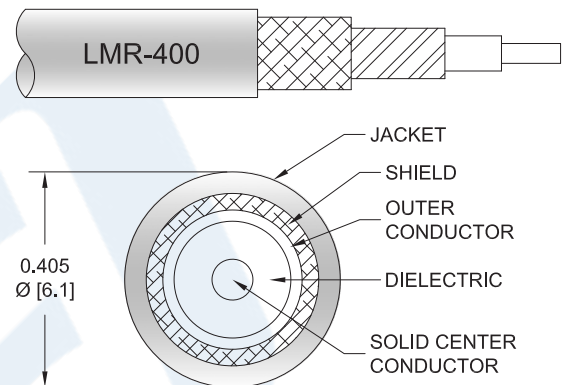

#### Applications

- General Purpose
- Laboratory Use

#### Description

Pasternack's PE3C2485 type N male to TNC male right angle cable using LMR-400 coax is part of our full line of RF components available for same-day shipping. Pasternack's flexible RF cable assemblies are ideal for applications where tight bends and flexure are required. This Pasternack type N to TNC cable assembly has a male to male gender configuration with 50 ohm flexible LMR-400 coax. The PE3C2485 type N male to TNC male cable assembly operates to 5.8 GHz. The right angle TNC interface on the LMR-400 cable allows for easier connections in tight spaces. The double shielding of this Pasternack cable assembly provides excellent shielding effectiveness of better than 90 dB.

Custom versions of most RF cable assemblies can be built and shipped same day. Custom cable assembly lengths can be obtained by specifying the desired length on the web site at time of order or by contacting a sales representative. Other available RF cable assembly value added services include connector orientation or clocking, heat shrink booting and custom labeling. RF testing can also be performed to document the electrical performance of your cable assembly.

Click the following link (or enter part number in "SEARCH" on website) to obtain additional part information including price, inventory and certifications: [Clamped N Male to TNC Male Right Angle Low Loss Cable Using LMR-400 Coax with Times Microwave Components PE3C2485](#)



## Clamped N Male to TNC Male Right Angle Low Loss Cable Using LMR-400 Coax with Times Microwave Components

### TECHNICAL DATA SHEET

**PE3C2485**

#### Electrical Specifications

Description	Minimum	Typical	Maximum	Units
Frequency Range	DC		5.8	GHz
VSWR			1.4:1	
Velocity of Propagation		85		%
RF Shielding	90			dB
Group Delay		1.2 [3.94]		ns/ft [ns/m]
Capacitance		23.9 [78.41]		pF/ft [pF/m]
Inductance		0.06 [0.2]		uH/ft [uH/m]
DC Resistance Inner Conductor		1.39 [4.56]		$\Omega$ /1000ft [ $\Omega$ /Km]
DC Resistance Outer Conductor		1.65 [5.41]		$\Omega$ /1000ft [ $\Omega$ /Km]
Jacket Spark			8,000	Vrms

#### Specifications by Frequency

Part Number	Length	Description	F1	F2	F3	F4	F5	Units	Weight (lbs)
		Frequency	250	500	1000	2500	5800	MHz	
PE3C2485	Custom Lengths Available	Insertion Loss (Typ.)	0.02	0.03	0.04	0.07	0.11	dB/ft	
			0.07	0.1	0.14	0.23	0.36	dB/m	
PE3C2485-12	12 inch	Insertion Loss (Typ.)	0.32	0.33	0.35	0.37	0.41	dB	0.325
PE3C2485-24	24 inch	Insertion Loss (Typ.)	0.34	0.36	0.39	0.44	0.52	dB	0.393
PE3C2485-36	36 inch	Insertion Loss (Typ.)	0.36	0.39	0.43	0.51	0.63	dB	0.46
PE3C2485-48	48 inch	Insertion Loss (Typ.)	0.38	0.42	0.47	0.58	0.74	dB	0.527
PE3C2485-60	60 inch	Insertion Loss (Typ.)	0.4	0.44	0.51	0.64	0.84	dB	0.594

The insertion loss data for the base model does not include loss due to the connectors. Each length includes insertion loss due to the connectors.

Loss due to Connector 1:	0.1 dB
Loss due to Connector 2:	0.2 dB
Base Weight:	0.325 pounds
Additional Weight per Inch:	0.00559 pounds

#### Mechanical Specifications

##### Cable Assembly

Weight 0.325 lbs [147.42 g]

Click the following link (or enter part number in "SEARCH" on website) to obtain additional part information including price, inventory and certifications: [Clamped N Male to TNC Male Right Angle Low Loss Cable Using LMR-400 Coax with Times Microwave Components PE3C2485](#)



## Clamped N Male to TNC Male Right Angle Low Loss Cable Using LMR-400 Coax with Times Microwave Components

### TECHNICAL DATA SHEET

**PE3C2485**

#### Cable

Cable Type	LMR-400
Impedance	50 Ohms
Inner Conductor Type	Solid
Inner Conductor Material and Plating	Copper Clad Aluminum
Dielectric Type	PE (F)
Number of Shields	2
Shield Layer 1	Aluminum Tape
Shield Layer 2	Tinned Copper Braid
Jacket Material	PE, Black
Jacket Diameter	0.405 in [10.29 mm]
One Time Minimum Bend Radius	1 in [25.4 mm]
Repeated Minimum Bend Radius	4 in [101.6 mm]
Bending Moment	0.5 lbs-ft [0.68 N-m]
Flat Plate Crush	40 lbs/in [0.71 Kg/mm]
Tensile Strength	160 lbs [72.57 Kg]

#### Connectors

Description	Connector 1	Connector 2
Type	N Male Threaded	TNC Male Right Angle Threaded
Impedance	50 Ohms	50 Ohms
Mating Cycles		500
Contact Material and Plating	Beryllium Copper, Gold	Brass, Silver
Contact Plating Specification	1.27 $\mu$ m minimum	
Dielectric Type	PTFE	PTFE
Body Material and Plating	Brass, Tri-Metal	Brass, Silver
Body Plating Specification	2 $\mu$ m minimum	
Coupling Nut Material and Plating	Brass, Tri-Metal	Brass, Silver
Coupling Nut Plating Specification	2 $\mu$ m minimum	
Hex Size	20.57 mm	
Torque	44 in-lbs [4.97 Nm]	

#### Environmental Specifications

##### Temperature

Operating Range	-40 to +85 deg C
-----------------	------------------

Click the following link (or enter part number in "SEARCH" on website) to obtain additional part information including price, inventory and certifications: [Clamped N Male to TNC Male Right Angle Low Loss Cable Using LMR-400 Coax with Times Microwave Components PE3C2485](#)



## Clamped N Male to TNC Male Right Angle Low Loss Cable Using LMR-400 Coax with Times Microwave Components

### TECHNICAL DATA SHEET

PE3C2485

**Compliance Certifications** (see [product page](#) for current document)

#### Plotted and Other Data

Notes:

#### How to Order

Part Number Configuration:

PE3C2485 - xx uu

Unit of Measure:  
cm = Centimeters  
<blank> = Inches  
Length  
Base Number

Example: PE3C2485-12 = 12 inches long cable  
PE3C2485-100cm = 100 cm long cable

Clamped N Male to TNC Male Right Angle Low Loss Cable Using LMR-400 Coax with Times Microwave Components from Pasternack Enterprises has same day shipment for domestic and International orders. Our RF, microwave and millimeter wave products maintain a 99.4% availability and are part of the broadest selection in the industry.

Click the following link (or enter part number in "SEARCH" on website) to obtain additional part information including price, inventory and certifications: [Clamped N Male to TNC Male Right Angle Low Loss Cable Using LMR-400 Coax with Times Microwave Components PE3C2485](#)

URL: <https://www.pasternack.com/clamped-n-male-to-tnc-male-low-loss-cable-using-lmr-400-pe3c2485-p.aspx>

The information contained in this document is accurate to the best of our knowledge and representative of the part described herein. It may be necessary to make modifications to the part and/or the documentation of the part, in order to implement improvements. Pasternack reserves the right to make such changes as required. Unless otherwise stated, all specifications are nominal. Pasternack does not make any representation or warranty regarding the suitability of the part described herein for any particular purpose, and Pasternack does not assume any liability arising out of the use of any part or documentation.

# PE3C2485 CAD Drawing

Clamped N Male to TNC Male Right Angle Low Loss Cable Using LMR-400 Coax with Times Microwave Components

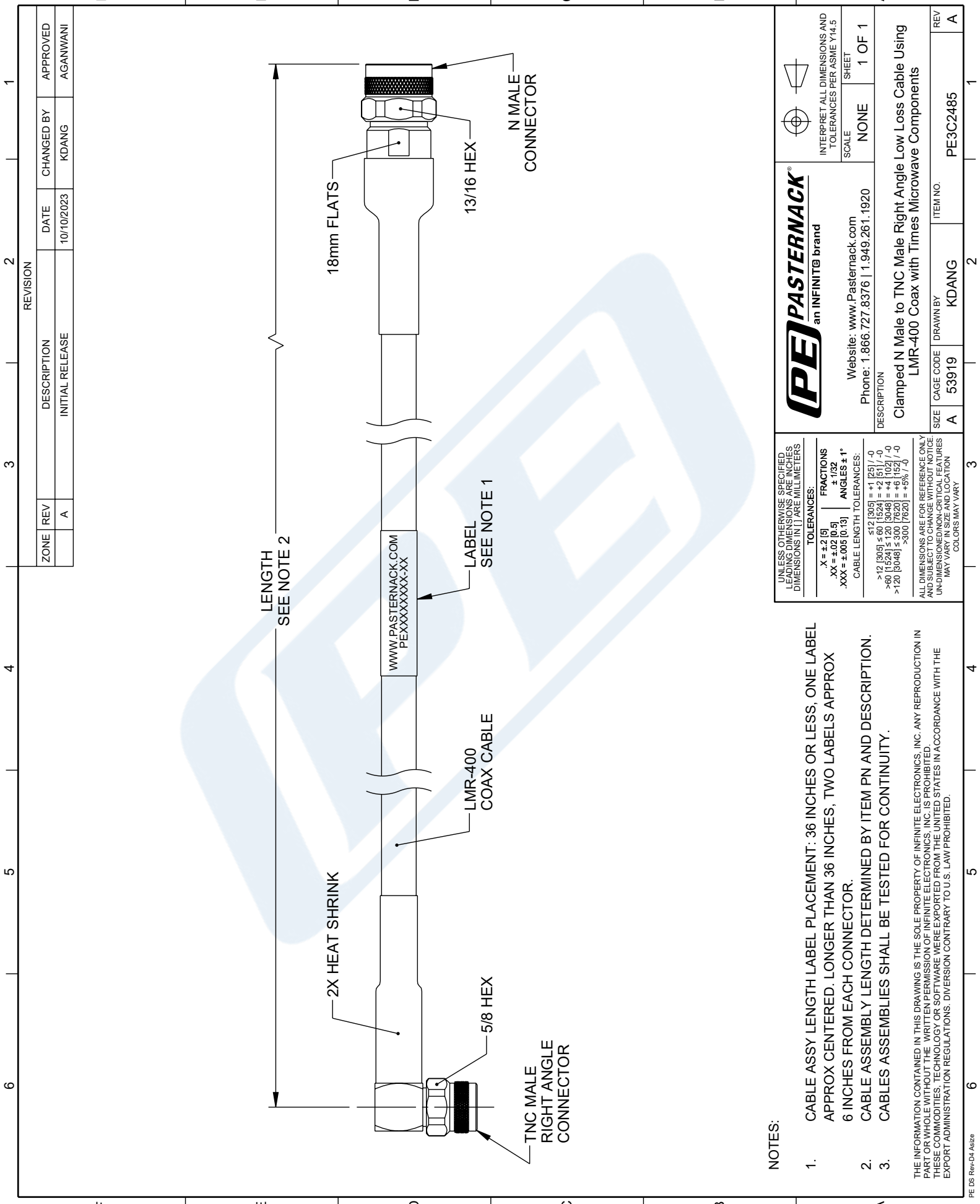

REVISION					
ZONE	REV	DESCRIPTION	DATE	CHANGED BY	APPROVED
	A	INITIAL RELEASE	10/10/2023	KDANG	AGANWANI

<p>UNLESS OTHERWISE SPECIFIED LEADING DIMENSIONS ARE IN INCHES DIMENSIONS IN [ ] ARE MILLIMETERS</p> <p><b>TOLERANCES:</b></p> <p>.X = ±.2 [5]</p> <p>.XX = ±.02 [0.5]</p> <p>.XXX = ±.005 [0.13]</p> <p>FRACTIONS ± 1/32</p> <p>ANGLES ± 1°</p> <p>CABLE LENGTH TOLERANCES:</p> <p>≤12 [305] = +1 [25] / -0</p> <p>&gt;12 [305] ≤ 60 [1524] = +2 [51] / -0</p> <p>&gt;60 [1524] ≤ 120 [3048] = +4 [102] / -0</p> <p>&gt;120 [3048] ≤ 300 [7620] = +.93 [ ] / -0</p> <p>&gt;300 [7620] = +.98 [ ] / -0</p>		<p>INTERPRET ALL DIMENSIONS AND TOLERANCES PER ASME Y14.5</p> <p>SCALE NONE</p> <p>SHEET 1 OF 1</p>
--	--	---

<p><b>PE PASTERNAK</b> an INFINITIB brand</p> <p>Website: www.Pasternack.com Phone: 1.866.727.8376   1.949.261.1920</p>		<p>DESCRIPTION</p> <p>Clamped N Male to TNC Male Right Angle Low Loss Cable Using LMR-400 Coax with Times Microwave Components</p>
<p>SIZE A</p> <p>CABLE CODE 53919</p>	<p>DRAWN BY KDANG</p>	<p>ITEM NO. PE3C2485</p>

- NOTES:
- CABLE ASSY LENGTH LABEL PLACEMENT: 36 INCHES OR LESS, ONE LABEL APPROX CENTERED. LONGER THAN 36 INCHES, TWO LABELS APPROX 6 INCHES FROM EACH CONNECTOR.
  - CABLE ASSEMBLY LENGTH DETERMINED BY ITEM PN AND DESCRIPTION.
  - CABLES ASSEMBLIES SHALL BE TESTED FOR CONTINUITY.

THE INFORMATION CONTAINED IN THIS DRAWING IS THE SOLE PROPERTY OF INFINITE ELECTRONICS, INC. ANY REPRODUCTION IN PART OR WHOLE WITHOUT THE WRITTEN PERMISSION OF INFINITE ELECTRONICS, INC. IS PROHIBITED. THESE COMMODITIES, TECHNOLOGY OR SOFTWARE WERE EXPORTED FROM THE UNITED STATES IN ACCORDANCE WITH THE EXPORT ADMINISTRATION REGULATIONS. DIVERSION CONTRARY TO U.S. LAW PROHIBITED.