



Black FAKRA Plug to FAKRA Jack Low
Loss Cable Using PE-C100 Coax

RF Cable Assemblies Technical Data Sheet

PE3C6305

Configuration

- Connector 1: FAKRA Plug
- Connector 2: FAKRA Jack
- Cable Type: PE-C100-LSZH

Features

- Max Frequency 4 GHz
- Shielding Effectivity > 90 dB
- 66% Phase Velocity
- Double Shielded
- PVC Jacket

Applications

- General Purpose
- Laboratory Use

Description

Pasternack's PE3C6305 black FAKRA plug to FAKRA jack cable using PE-C100 coax is part of our full line of RF components available for same-day shipping. Pasternack's flexible RF cable assemblies are ideal for applications where tight bends and flexure are required. This Pasternack FAKRA to FAKRA cable assembly has a plug to jack gender configuration with 50 ohm flexible PE-C100-LSZH coax. The PE3C6305 FAKRA plug to FAKRA jack cable assembly operates to 4 GHz. The double shielding of this Pasternack cable assembly provides excellent shielding effectiveness of better than 90 dB.

Custom versions of most RF cable assemblies can be built and shipped same day. Custom cable assembly lengths can be obtained by specifying the desired length on the web site at time of order or by contacting a sales representative. Other available RF cable assembly value added services include connector orientation or clocking, heat shrink booting and custom labeling. RF testing can also be performed to document the electrical performance of your cable assembly.

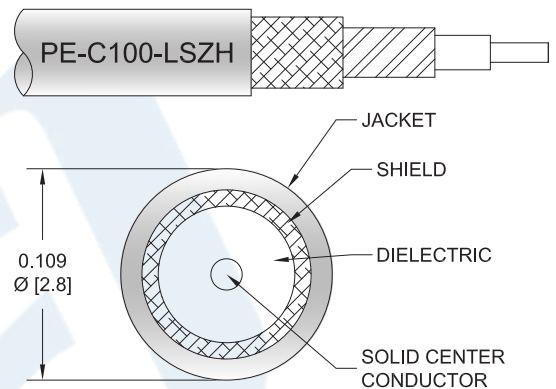

Click the following link (or enter part number in "SEARCH" on website) to obtain additional part information including price, inventory and certifications: [Black FAKRA Plug to FAKRA Jack Low Loss Cable Using PE-C100 Coax PE3C6305](#)



Black FAKRA Plug to FAKRA Jack Low Loss Cable Using PE-C100 Coax

RF Cable Assemblies Technical Data Sheet

PE3C6305

Electrical Specifications

Description	Minimum	Typical	Maximum	Units
Frequency Range	DC		4	GHz
VSWR			1.4:1	
Velocity of Propagation		66		%
RF Shielding	90			dB
Capacitance		30.8 [101.05]		pF/ft [pF/m]
Jacket Spark			2,000	Vrms

Specifications by Frequency

Description	F1	F2	F3	F4	F5	Units
Frequency	0.1	0.25	0.5	1	4	GHz
Insertion Loss (Typ.)	0.07	0.115	0.166	0.24	0.522	dB/ft
	0.23	0.38	0.54	0.79	1.71	dB/m

Electrical Specification Notes:

Insertion Loss does not include the loss of the connectors. Insertion Loss is estimated as 0.1 dB per connector.

Mechanical Specifications

Cable Assembly

Weight 0.023 lbs [10.43 g]

Cable

Cable Type PE-C100-LSZH
 Impedance 50 Ohms
 Inner Conductor Type Solid
 Inner Conductor Material and Plating Copper Clad Steel
 Dielectric Type PE
 Number of Shields 2
 Shield Layer 1 Aluminum Tape
 Shield Layer 2 Tinned Copper Braid
 Jacket Material PVC, Black
 Jacket Diameter 0.11 in [2.79 mm]

One Time Minimum Bend Radius 0.25 in [6.35 mm]

Repeated Minimum Bend Radius 1 in [25.4 mm]

Click the following link (or enter part number in "SEARCH" on website) to obtain additional part information including price, inventory and certifications: [Black FAKRA Plug to FAKRA Jack Low Loss Cable Using PE-C100 Coax PE3C6305](#)



Black FAKRA Plug to FAKRA Jack Low Loss Cable Using PE-C100 Coax

RF Cable Assemblies Technical Data Sheet

PE3C6305

Connectors

Description	Connector 1	Connector 2
Type	FAKRA Plug	FAKRA Jack
Impedance	50 Ohms	50 Ohms
Configuration	Straight	Straight
Contact Material and Plating	Phosphor Bronze, Gold	Phosphor Bronze, Gold
Dielectric Type	PTFE	PTFE
Outer Conductor Material and Plating	Brass, Nickel	Brass, Nickel
Body Material and Plating	Plastic	Plastic

Environmental Specifications

Temperature

Operating Range

-40 to +85 deg C

Compliance Certifications (see [product page](#) for current document)

Plotted and Other Data

Notes:

Click the following link (or enter part number in "SEARCH" on website) to obtain additional part information including price, inventory and certifications: [Black FAKRA Plug to FAKRA Jack Low Loss Cable Using PE-C100 Coax PE3C6305](#)



Black FAKRA Plug to FAKRA Jack Low
Loss Cable Using PE-C100 Coax

RF Cable Assemblies Technical Data Sheet

PE3C6305

How to Order

Part Number Configuration:

PE3C6305

- **xx**

uu

Unit of Measure:
cm = Centimeters
<blank> = Inches
Length
Base Number

Example: PE3C6305-12 = 12 inches long cable
PE3C6305-100cm = 100 cm long cable

Black FAKRA Plug to FAKRA Jack Low Loss Cable Using PE-C100 Coax from Pasternack Enterprises has same day shipment for domestic and International orders. Our RF, microwave and millimeter wave products maintain a 99.4% availability and are part of the broadest selection in the industry.

Click the following link (or enter part number in "SEARCH" on website) to obtain additional part information including price, inventory and certifications: [Black FAKRA Plug to FAKRA Jack Low Loss Cable Using PE-C100 Coax PE3C6305](#)

URL: <https://www.pasternack.com/fakra-plug-to-fakra-jack-low-loss-cable-using-pe-c100-pe3c6305-p.aspx>

The information contained in this document is accurate to the best of our knowledge and representative of the part described herein. It may be necessary to make modifications to the part and/or the documentation of the part, in order to implement improvements. Pasternack reserves the right to make such changes as required. Unless otherwise stated, all specifications are nominal. Pasternack does not make any representation or warranty regarding the suitability of the part described herein for any particular purpose, and Pasternack does not assume any liability arising out of the use of any part or documentation.

PE3C6305 CAD Drawing

Black FAKRA Plug to FAKRA Jack Low Loss Cable Using PE-C100 Coax

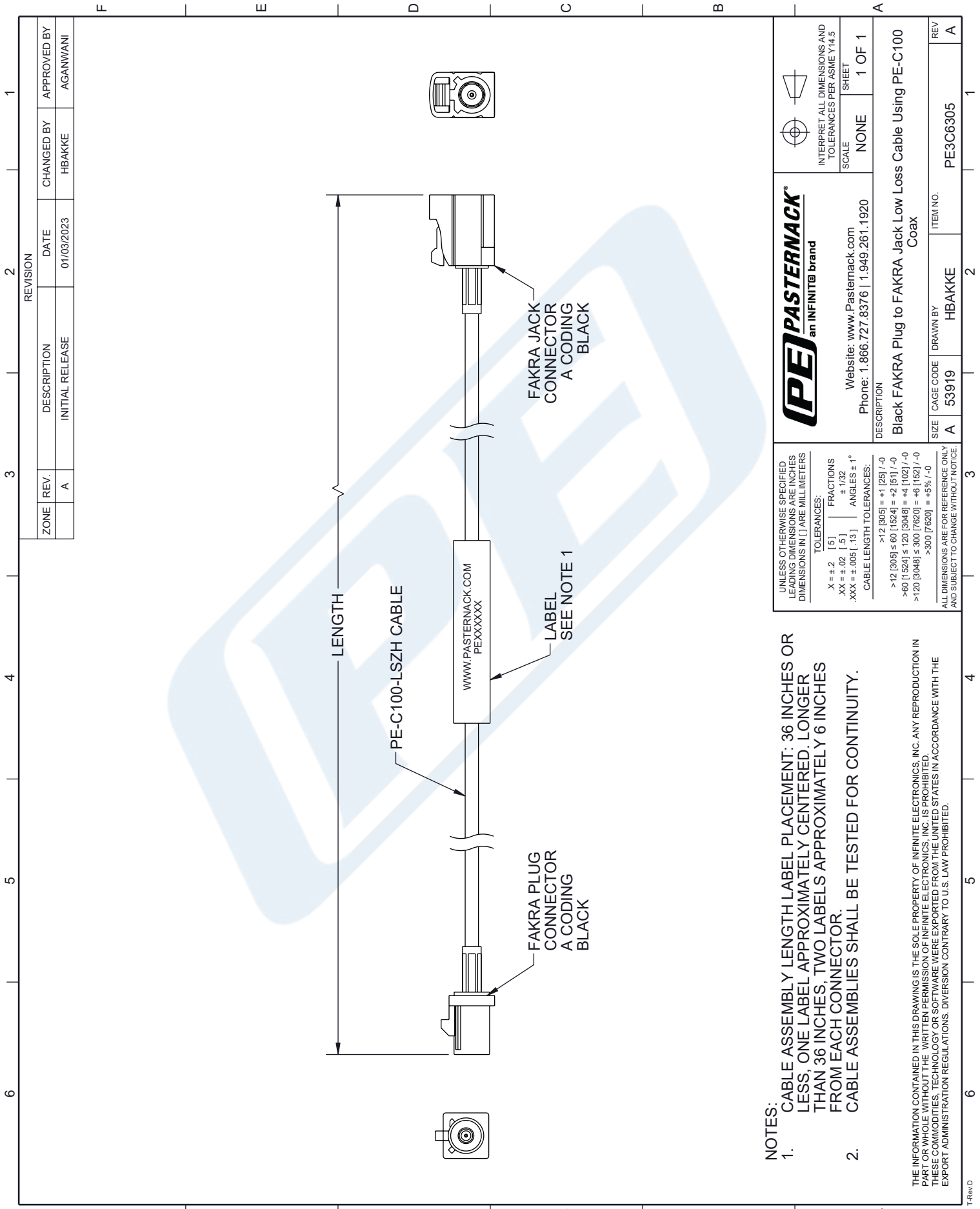

- NOTES:**
- CABLE ASSEMBLY LENGTH LABEL PLACEMENT: 36 INCHES OR LESS, ONE LABEL APPROXIMATELY CENTERED. LONGER THAN 36 INCHES, TWO LABELS APPROXIMATELY 6 INCHES FROM EACH CONNECTOR.
 - CABLE ASSEMBLIES SHALL BE TESTED FOR CONTINUITY.

THE INFORMATION CONTAINED IN THIS DRAWING IS THE SOLE PROPERTY OF INFINITE ELECTRONICS, INC. ANY REPRODUCTION IN PART OR WHOLE WITHOUT THE WRITTEN PERMISSION OF INFINITE ELECTRONICS, INC. IS PROHIBITED. THESE COMMODITIES, TECHNOLOGY OR SOFTWARE WERE EXPORTED FROM THE UNITED STATES IN ACCORDANCE WITH THE EXPORT ADMINISTRATION REGULATIONS. DIVERSION CONTRARY TO U.S. LAW PROHIBITED.

UNLESS OTHERWISE SPECIFIED LEADING DIMENSIONS ARE INCHES DIMENSIONS IN [] ARE MILLIMETERS	
TOLERANCES:	
X = ±.2 [5]	FRACTIONS ± 1/32
.XX = ±.02 [5]	ANGLES ± 1°
.XXX = ±.005 [13]	
CABLE LENGTH TOLERANCES:	
>12 [305]	±.1 [25] / -0
>12 [305] ≤ 60 [1524]	±.2 [51] / -0
>60 [1524] ≤ 120 [3048]	±.4 [102] / -0
>120 [3048] ≤ 300 [7620]	±.6 [152] / -0
>300 [7620]	±.8 [203] / -0
ALL DIMENSIONS ARE FOR REFERENCE ONLY AND SUBJECT TO CHANGE WITHOUT NOTICE	

PE PASTERNAK an INFINITE brand	
Website: www.Pasternack.com Phone: 1.866.727.8376 1.949.261.1920	
INTERPRET ALL DIMENSIONS AND TOLERANCES PER ASME Y14.5	SHEET 1 OF 1
DESCRIPTION Black FAKRA Plug to FAKRA Jack Low Loss Cable Using PE-C100 Coax	
SIZE A	CAGE CODE 53919
DRAWN BY HBAKKE	ITEM NO. PE3C6305
REV A	REV A