

SMA Male to Black FAKRA Plug Low Loss Cable Using PE-C100-LSZH Coax



PE3C6394

Configuration

- Connector 1: SMA Male
- Connector 2: FAKRA Plug
- Cable Type: PE-C100-LSZH
- Coax Flex Type: Flexible

Features

- Max Frequency 4 GHz
- Shielding Effectivity > 90 dB
- 66% Phase Velocity
- Double Shielded
- PVC Jacket

Applications

- General Purpose
- Laboratory Use

Description

Pasternack's PE3C6394 SMA male to black FAKRA plug cable using PE-C100-LSZH coax is part of our full line of RF components available for same-day shipping. Pasternack's flexible RF cable assemblies are ideal for applications where tight bends and flexure are required. This Pasternack SMA to FAKRA cable assembly has a male to plug gender configuration with 50 ohm flexible PE-C100-LSZH coax. The PE3C6394 SMA male to FAKRA plug cable assembly operates to 4 GHz. The double shielding of this Pasternack cable assembly provides excellent shielding effectiveness of better than 90 dB.

Custom versions of most RF cable assemblies can be built and shipped same day. Custom cable assembly lengths can be obtained by specifying the desired length on the web site at time of order or by contacting a sales representative. Other available RF cable assembly value added services include connector orientation or clocking, heat shrink booting and custom labeling. RF testing can also be performed to document the electrical performance of your cable assembly.

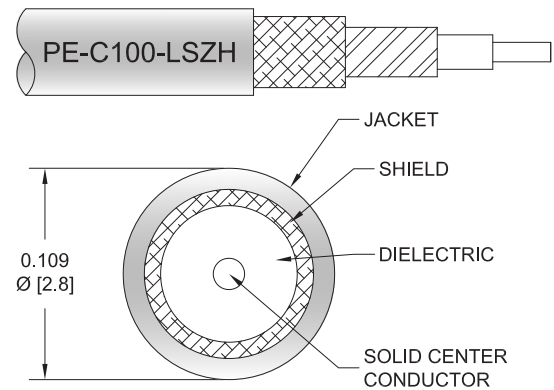

Electrical Specifications

Description	Minimum	Typical	Maximum	Units
Frequency Range	DC		4	GHz
VSWR			1.4:1	
Velocity of Propagation		66		%
RF Shielding	90			dB
Capacitance		30.8 [101.05]		pF/ft [pF/m]
Operating Voltage (AC)			335	Vrms
Jacket Spark			2,000	Vrms

Specifications by Frequency

SMA Male to Black FAKRA Plug Low Loss Cable Using PE-C100-LSZH Coax



PE3C6394

Part Number	Length	Description	F1	F2	F3	F4	F5	Units	Weight (lbs)
			Frequency		100	250	500	1000	
PE3C6394	Custom Lengths Available	Insertion Loss (Typ.)	0.07	0.115	0.166	0.24	0.522	dB/ft	
			0.23	0.38	0.55	0.79	1.72	dB/m	
PE3C6394-12	12 inch	Insertion Loss (Typ.)	0.47	0.52	0.57	0.64	0.93	dB	0.027
PE3C6394-24	24 inch	Insertion Loss (Typ.)	0.54	0.63	0.74	0.88	1.45	dB	0.038
PE3C6394-36	36 inch	Insertion Loss (Typ.)	0.61	0.75	0.9	1.12	1.97	dB	0.048
PE3C6394-48	48 inch	Insertion Loss (Typ.)	0.68	0.86	1.07	1.36	2.49	dB	0.058
PE3C6394-60	60 inch	Insertion Loss (Typ.)	0.75	0.98	1.23	1.6	3.01	dB	0.068

The insertion loss data for the base model does not include loss due to the connectors. Each length includes insertion loss due to the connectors.

Loss due to Connector 1:	0.1 dB
Loss due to Connector 2:	0.3 dB
Base Weight:	0.027 pounds
Additional Weight per Inch:	0.00084 pounds

Mechanical Specifications

Cable Assembly

Width/Diameter	0.5 in [12.7 mm]
Weight	0.027 lbs [12.25 g]

Cable

Cable Type	PE-C100-LSZH
Impedance	50 Ohms
Inner Conductor Type	Solid
Inner Conductor Material and Plating	Copper Clad Steel
Dielectric Type	PE
Number of Shields	2
Shield Layer 1	Aluminum Tape
Shield Layer 2	Tinned Copper Braid
Jacket Material	PVC, Black
Jacket Diameter	0.11 in [2.79 mm]
One Time Minimum Bend Radius	0.25 in [6.35 mm]
Repeated Minimum Bend Radius	1 in [25.4 mm]

SMA Male to Black FAKRA Plug Low Loss Cable Using PE-C100-LSZH Coax



PE3C6394

Connectors

Description	Connector 1	Connector 2
Type	SMA Male	FAKRA Plug
Specification	MIL-STD-348A	
Impedance	50 Ohms	50 Ohms
Configuration	Straight	Straight
Color		BK
Mating Cycles	500	
Contact Material and Plating	Brass, Gold	Phosphor Bronze, Gold
Contact Plating Specification	30 µin minimum	
Dielectric Type	PTFE	PTFE
Outer Conductor Material and Plating		Brass, Nickel
Body Material and Plating	Brass, Nickel	Plastic
Body Plating Specification	100 µin minimum	
Coupling Nut Material and Plating	Brass, Nickel	
Coupling Nut Plating Specification	100 µin minimum	
Hex Size	5/16 inch	
Torque	3 in-lbs 0.34 Nm	

Environmental Specifications

Operating Range Temperature -40 to +85 deg C

Compliance Certifications (see [product page](#) for current document)

Plotted and Other Data

Notes:

SMA Male to Black FAKRA Plug Low Loss Cable Using PE-C100-LSZH Coax



PE3C6394

Typical Performance Data

How to Order

Part Number Configuration:

PE3C6394

- xx

uu

Unit of Measure:
cm = Centimeters
<blank> = Inches
Length
Base Number

Example: PE3C6394-12 = 12 inches long cable
PE3C6394-100cm = 100 cm long cable

SMA Male to Black FAKRA Plug Low Loss Cable Using PE-C100-LSZH Coax from Pasternack Enterprises has same day shipment for domestic and International orders. Our RF, microwave and millimeter wave products maintain a 99.4% availability and are part of the broadest selection in the industry.

Click the following link (or enter part number in "SEARCH" on website) to obtain additional part information including price, inventory and certifications: [SMA Male to Black FAKRA Plug Low Loss Cable Using PE-C100-LSZH Coax PE3C6394](#)

URL: <https://www.pasternack.com/sma-male-to-fakra-plug-low-loss-cable-using-pe-c100-lszh-pe3c6394-p.aspx>

The information contained within this document is accurate to the best of our knowledge and representative of the part described herein. It may be necessary to make modifications to the part and/or the documentation of the part in order to implement improvements. Pasternack Enterprises reserves the right to make such changes as required. Unless otherwise stated, all specifications are nominal. Pasternack Enterprises does not make any representation or warranty regarding the suitability of the part described herein for any particular purpose, and Pasternack Enterprises does not assume liability arising out of the use of any part or document.

PE3C6394 CAD Drawing

SMA Male to Black FAKRA Plug Low Loss Cable Using PE-C100-LSZH Coax

