

N Male to TNC Male Low Loss Cable Using LMR-240 Coax with Times Microwave Components



PE3W02292

Configuration

- Connector 1: N Male
- Connector 2: TNC Male
- Cable Type: LMR-240
- Coax Flex Type: Flexible

Features

- Max Frequency 6 GHz
- Shielding Effectivity > 90 dB
- 84% Phase Velocity
- Double Shielded
- PE Jacket

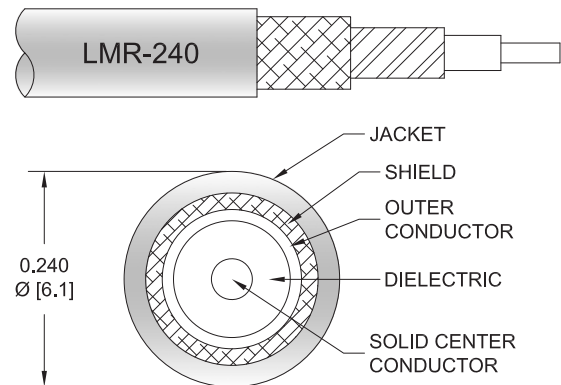

Applications

- General Purpose
- Laboratory Use

Description

Pasternack's PE3W02292 type N male to TNC male cable using LMR-240 coax is part of our full line of RF components available for same-day shipping. Pasternack's flexible RF cable assemblies are ideal for applications where tight bends and flexure are required. This Pasternack type N to TNC cable assembly has a male to male gender configuration with 50 ohm flexible LMR-240 coax. The PE3W02292 type N male to TNC male cable assembly operates to 6 GHz. The double shielding of this Pasternack cable assembly provides excellent shielding effectiveness of better than 90 dB.

Custom versions of most RF cable assemblies can be built and shipped same day. Custom cable assembly lengths can be obtained by specifying the desired length on the web site at time of order or by contacting a sales representative. Other available RF cable assembly value added services include connector orientation or clocking, heat shrink booting and custom labeling. RF testing can also be performed to document the electrical performance of your cable assembly.

Electrical Specifications

Description	Minimum	Typical	Maximum	Units
Frequency Range	DC		6	GHz
VSWR			1.4:1	
Velocity of Propagation		84		%
RF Shielding	90			dB
Group Delay		1.21 [3.97]		ns/ft [ns/m]
Capacitance		24.2 [79.4]		pF/ft [pF/m]
Inductance		0.06 [0.2]		uH/ft [uH/m]
DC Resistance Inner Conductor		3.2 [10.5]		Ohms/1000ft [Ohms/Km]
DC Resistance Outer Conductor		3.89 [12.76]		Ohms/1000ft [Ohms/Km]

N Male to TNC Male Low Loss Cable Using LMR-240 Coax with Times Microwave Components



PE3W02292

Electrical Specifications

Description	Minimum	Typical	Maximum	Units
Jacket Spark			5,000	Vrms

Specifications by Frequency

Part Number	Length	Description	F1	F2	F3	F4	F5	Units	Weight (lbs)
			Frequency					MHz	
PE3W02292	Custom Lengths Available	Insertion Loss (Typ.)	0.039	0.055	0.079	0.129	0.204	dB/ft	
			0.13	0.19	0.26	0.43	0.67	dB/m	
PE3W02292-12	12 In	Insertion Loss (Typ.)	0.42	0.44	0.46	0.51	0.59	dB	0.162
PE3W02292-24	24 In	Insertion Loss (Typ.)	0.46	0.49	0.54	0.64	0.79	dB	0.195
PE3W02292-36	36 In	Insertion Loss (Typ.)	0.5	0.55	0.62	0.77	1	dB	0.228
PE3W02292-48	48 In	Insertion Loss (Typ.)	0.54	0.6	0.7	0.9	1.2	dB	0.261
PE3W02292-60	60 In	Insertion Loss (Typ.)	0.58	0.66	0.78	1.03	1.4	dB	0.294

The insertion loss data for the base model does not include loss due to the connectors. Each length includes insertion loss due to the connectors.

Loss due to Connector 1:	0.1 dB
Loss due to Connector 2:	0.28 dB
Base Weight:	0.162 pounds
Additional Weight per Inch:	0.00275 pounds

Mechanical Specifications

Cable Assembly

Width/Diameter	0.5 in [12.7 mm]
Weight	0.162 lbs [73.48 g]

Cable

Cable Type	LMR-240
Impedance	50 Ohms
Inner Conductor Type	Solid
Inner Conductor Material and Plating	Copper
Dielectric Type	PE (F)
Number of Shields	2
Shield Layer 1	Aluminum Tape
Shield Layer 2	Tinned Copper Braid
Jacket Material	PE, Black
Jacket Diameter	0.24 in [6.1 mm]
One Time Minimum Bend Radius	0.75 in [19.05 mm]
Repeated Minimum Bend Radius	2.5 in [63.5 mm]
Bending Moment	0.25 lbs-ft [0.34 N-m]
Flat Plate Crush	20 lbs/in [0.36 Kg/mm]
Tensile Strength	80 lbs [36.29 Kg]

N Male to TNC Male Low Loss Cable Using LMR-240 Coax with Times Microwave Components



PE3W02292

Connectors

Description	Connector 1	Connector 2
Type	N Male	TNC Male
Specification	MIL-STD-348	
Impedance	50 Ohms	50 Ohms
Configuration	Straight	Straight
Mating Cycles		500
Contact Material and Plating	Beryllium Copper, Gold	Phosphor Bronze, Gold
Contact Plating Specification	ASTM-B488	50μ in. minimum
Dielectric Type	Teflon	Teflon
Body Material and Plating	Brass, Tri-Metal	Brass, Tri-Metal
Body Plating Specification	QQ-N-290	80μ in. minimum
Coupling Nut Material and Plating	Brass, Tri-Metal	Brass, Tri-Metal
Coupling Nut Plating Specification	QQ-N-290	80μ in. minimum
Torque		20 in-lbs 2.26 Nm

Environmental Specifications

Compliance Certifications (see [product page](#) for current document)

Plotted and Other Data

Notes:

N Male to TNC Male Low Loss Cable Using LMR-240 Coax with Times Microwave Components



PE3W02292

Typical Performance Data

How to Order

Part Number Configuration:

PE3W02292

- xx

uu

Unit of Measure:
cm = Centimeters
<blank> = Inches
Length
Base Number

Example: PE3W02292-12 = 12 inches long cable
PE3W02292-100cm = 100 cm long cable

N Male to TNC Male Low Loss Cable Using LMR-240 Coax with Times Microwave Components from Pasternack Enterprises has same day shipment for domestic and International orders. Our RF, microwave and millimeter wave products maintain a 99.4% availability and are part of the broadest selection in the industry.

Click the following link (or enter part number in "SEARCH" on website) to obtain additional part information including price, inventory and certifications: [N Male to TNC Male Low Loss Cable Using LMR-240 Coax with Times Microwave Components PE3W02292](#)

URL: <https://www.pasternack.com/n-male-to-tnc-male-low-loss-cable-using-lmr-240-pe3w02292-p.aspx>

The information contained within this document is accurate to the best of our knowledge and representative of the part described herein. It may be necessary to make modifications to the part and/or the documentation of the part in order to implement improvements. Pasternack Enterprises reserves the right to make such changes as required. Unless otherwise stated, all specifications are nominal. Pasternack Enterprises does not make any representation or warranty regarding the suitability of the part described herein for any particular purpose, and Pasternack Enterprises does not assume liability arising out of the use of any part or document.

PE3W02292 CAD Drawing

N Male to TNC Male Low Loss Cable Using LMR-240 Coax with Times Microwave Components

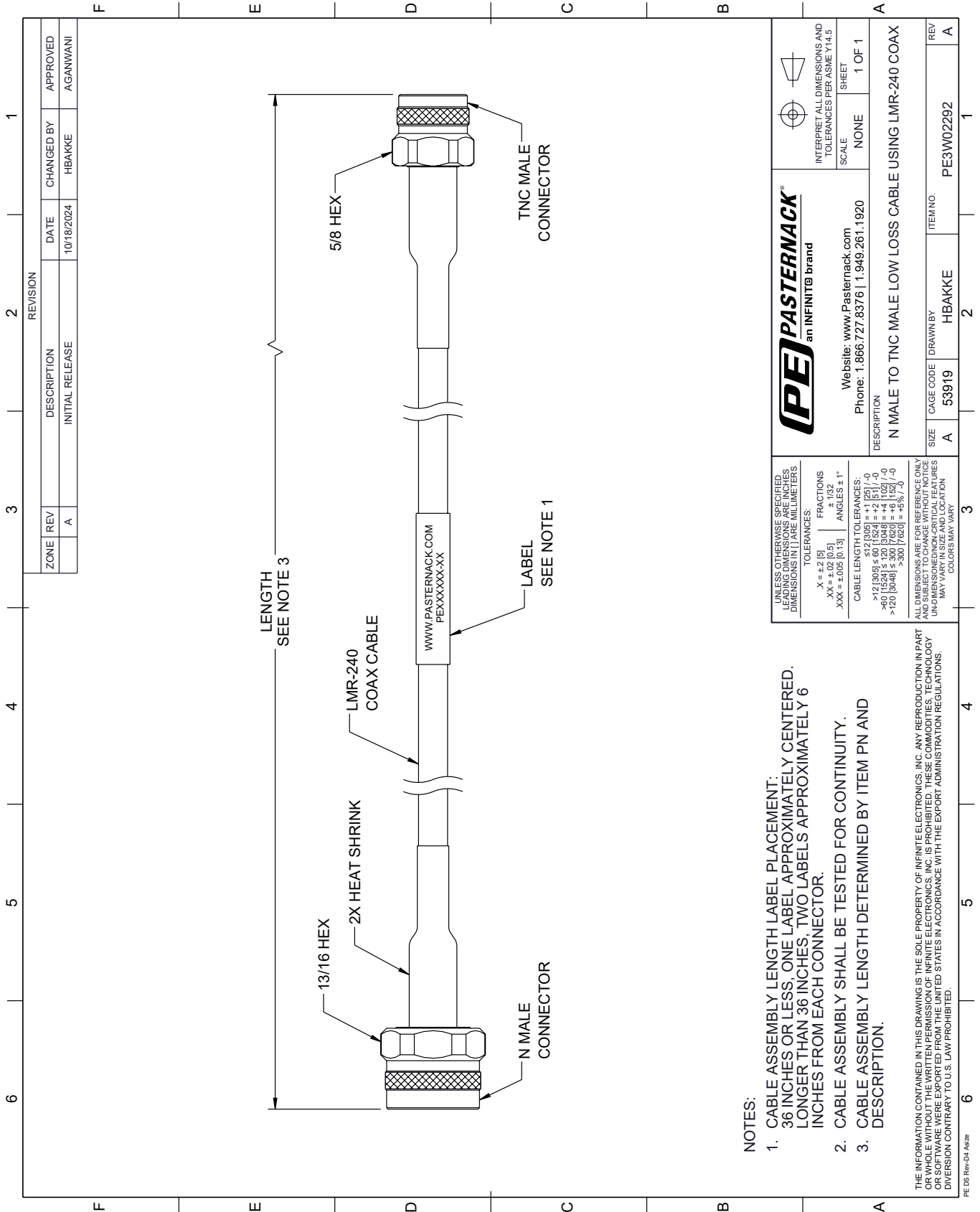

PE PASTERNAK
an INFINITO brand

Website: www.Pasternack.com
 Phone: 1.866.727.8376 | 1.949.261.1920

INTERPRET ALL DIMENSIONS AND TOLERANCES PER ASME Y14.5

SCALE: NONE
 SHEET: 1 OF 1

DESCRIPTION: N MALE TO TNC MALE LOW LOSS CABLE USING LMR-240 COAX

SIZE	CAGE CODE	DRAWN BY	ITEM NO.
A	53919	HBAKKE	PE3W02292

REV A