

NOTICE OF PROPRIETARY RIGHTS THIS DOCUMENT CONTAINS CONFIDENTIAL TECHNICAL DATA, INCLUDING TRADE SECRETS, PROPRIETARY TO TIMES MICROWAVE SYSTEMS. DISCLOSURE OF THIS DATA IS EXPRESSLY CONDITIONED UPON YOUR ASSENT THAT ITS USE IS LIMITED TO USE WITHIN YOUR COMPANY ONLY. ANY OTHER USE IS STRICTLY PROHIBITED WITHOUT THE PRIOR WRITTEN CONSENT OF TIMES MICROWAVE SYSTEMS.

SYM	REVISION DESCRIPTION	DFTM	DATE	APPD	DATE
A	RELEASED FOR PRODUCTION	K.A.M.	6/3/11	J.D.B.	6/3/11
B	CHANGED PER CDC #34607/36250	D.J.H.	9/24/12	J.D.B.	9/25/12

RECOMMENDED CABLE STRIPPING DIM'S.

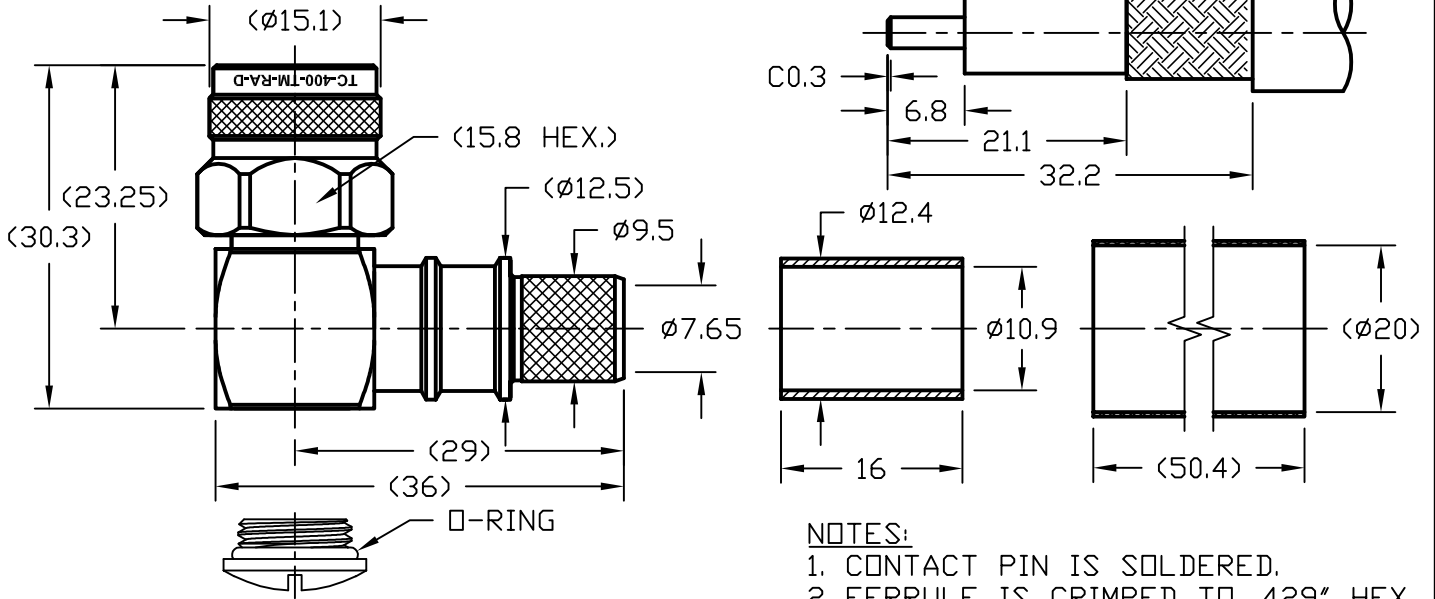

- NOTES:
 1. CONTACT PIN IS SOLDERED.
 2. FERRULE IS CRIMPED TO .429" HEX.

ALL PARTS SATISFIED ROHS REQUIREMENTS

MATERIALS AND PLATING		UNIT: MICRO-INCHES
BODY/SHELL	BRASS C3604	ALBALOY 80 MIN/COPPER
CONTACT PIN	BRASS C3604	GOLD 50 MIN/NICKEL/COPPER
INSULATOR	TEFLON MIL-P-19468	N/A
GASKET	SILICONE	RED
FERRULE	BRASS	ALBALOY 80 MIN/COPPER
SHRINK TUBING	PO	BLACK

ELECTRICAL CHARACTERISTICS	
Impedance	50 Ω
Frequency range	0~11GHz
Voltage rating	500V(rms)
Dielectric withstanding voltage	1000V
Contact resistance	Center contact ≤ 3 mΩ
	Outer contact ≤ 2 mΩ
Insulation resistance	≥ 5000MΩ
Insertion loss	According to the cable
RF-leakage	N/A
VSWR	≤ 1.35 MAX@0-6GHz

MECHANICAL CHARACTERISTICS	
Force to engage and disengage	N/A
Center contact retention force	6 lbs Min
Coupling torque	15 in-lbs Min
Coupling nut retention force	60 lbs Min
Durability	≥ 500 cycles

ENVIRONMENTAL CHARACTERISTICS	
Temperature range	-55°C - +125°C
Thermal Shock	MIL-STD-202, Method 107, Cond B
Vibration	MIL-STD-202, Method 204, Cond B
Shock	MIL-STD-202, Method 213, Cond I
Climatic Class	IEC 60068 55/155/56

MATERIAL: UNLESS OTHERWISE SPECIFIED	DFTM: K. A. M.	TIMES MICROWAVE SYSTEMS
	DATE: 6/3/11	
USED ON: 0-4	CHKD: J. D. B.	TC-400-TM-RA-D 90° TNC MALE FOR LMR400 CABLE
	DATE: 6/3/11	
SCALE: N/A	APPD: J. D. B.	1 of 1 SD3190-2671 B
	DATE: 6/3/11	
DWG. SIZE: A	DO NOT SCALE DRAWING	CODE IDENT: 68999

NOTICE OF PROPRIETARY RIGHTS THIS DOCUMENT CONTAINS CONFIDENTIAL TECHNICAL DATA, INCLUDING TRADE SECRETS, PROPRIETARY TO TIMES MICROWAVE SYSTEMS. DISCLOSURE OF THIS DATA IS EXPRESSLY CONDITIONED UPON YOUR ASSENT THAT ITS USE IS LIMITED TO USE WITHIN YOUR COMPANY ONLY. ANY OTHER USE IS STRICTLY PROHIBITED WITHOUT THE PRIOR WRITTEN CONSENT OF TIMES MICROWAVE SYSTEMS.

SYM	REVISION DESCRIPTION	DFTM	DATE	APPD	DATE
A	RELEASED FOR PRODUCTION	D. J. H.	12/11/12	J. D. B.	12/12/12

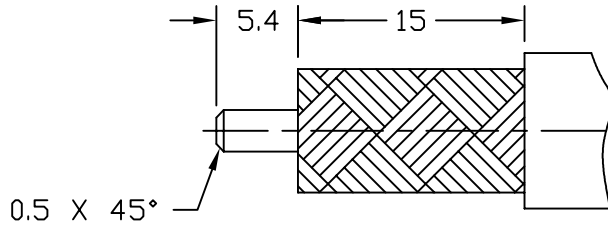

CABLE PREP.
USE CST-400
(3192-004)
.429" HEX.

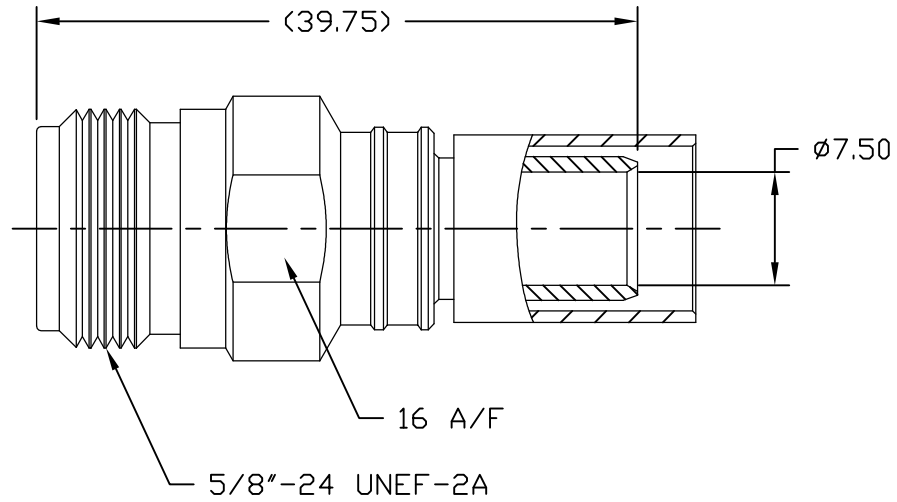

Reference Standard IEC60169-16

I. Electric Performance

Nominal Impedance(Ω): 50
 Frequency Range: DC-6GHz
 VSWR: $\leq 1.3(0-6\text{GHz})$
 Insert Loss(dB): ≤ 0.10
 Insulation resistance(M Ω): >5000
 Proof Voltage(V): 1500
 Conductor resistance(m Ω):
 outer conductor <0.4
 inner conductor <0.8

II. Mechanical Performance

Tensile force(cable-connect) 400N
 Torsion(cable-connect) 2N.m

III. Material and plating

Component	Material	Plating
Inner conductor	Spring Copper	Au >1.27 μm
Outer conductor	Brass	Copper-tin-zinc > 2 μm
Insulator	PTFE	

IV. Environment

Temp. range -55°C~+155°C
 Weather standard IEC 60068 55 / 155/ 56
 Thermal shock US MIL-STD 202, Meth.107, Cond.B
 Vibration US MIL-STD 202, Meth.204, Cond.B
 Shock US MIL-STD 202, Meth.213, Cond.I
 ROHS Compliant

V. Assembly: inner conductor soldered and outer conductor crimped

MATERIAL:	UNLESS OTHERWISE SPECIFIED ALL DIMENSIONS ARE IN mm MACHINED SURFACES FINISH N/A RMS MAX. REMOVE ALL BURRS N/A MAX. BREAK MACHINE CORNERS N/A MAX. FILLET R. TOLERANCES ON DECIMALS .XX \pm N/A .XXX \pm N/A ANGLES $\pm 1^\circ$ FRACTIONS \pm N/A	DFTM. D. J. H.	TIMES MICROWAVE SYSTEMS
		DATE 12/11/12	
USED ON: O-1		CHKD. J. D. B.	TC-400-NF-X N FEMALE FOR LMR-400 CABLE SOLDER/CRIMP/NO BRAID TRIM
		DATE 12/12/12	
SCALE: N/A	DWG. SIZE A	APPD. J. D. B.	SHEET 1 of 1 SD3190-2815 REV A
		DATE 12/12/12	
DO NOT SCALE DRAWING	CODE IDENT 68999		

LMR-[®]400-UF UltraFlex Communications Coax

Ideal for...

- Drop-in replacement for RG-8/9913 Air-Dielectric type Cable
- Jumper Assemblies in Wireless Communications Systems
- Short Antenna Feeder runs
- Any application that requires periodic/repeated flexing



• **LMR[®] - UltraFlex** has a stranded center conductor and rubber outer jacket designed for multiple bending/flexing cycles. It is used for both indoor and outdoor applications.

• **Flexibility** and bendability are hallmarks of the LMR-400-UF cable design. The flexible outer conductor enables the tightest bend radius available for any cable of similar size and performance.

• **Low Loss** is another hallmark feature of LMR-400-UF. Size for size LMR has the lowest loss of any flexible cable and comparable loss to semirigid hard-line cables.

• **RF Shielding** is 50 dB greater than typical single shielded coax (40 dB). The multi-ply bonded foil outer conductor is rated conservatively at > 90 dB (i.e. >180 dB between two adjacent cables).

• **Weatherability:** LMR-400-UF cables are designed for outdoor exposure and have a life expectancy in excess of 10 years.

• **Connectors:** A wide variety of connectors are available for LMR-400-UF cable, including all common interface types, reverse polarity, and solder-on center pins. Most LMR connectors employ crimp outer attachment using standard hex crimp sizes.

• **Cable Assemblies:** All LMR-400-UF cable types are available as pre-terminated cable assemblies. Refer to the section on FlexTech for further details.

Part Description				
Part Number	Application	Jacket	Color	Stock Code
LMR-400-UF	Indoor/Outdoor	TPE	Black	54040

Construction Specifications				
Description	Material	In.	(mm)	
Inner Conductor	Stranded BC	0.108	(2.74)	
Dielectric	Foam Polyethylene	0.285	(7.24)	
Outer Conductor	Aluminum Tape	0.291	(7.39)	
Overall Braid	Tinned Copper	0.320	(8.13)	
Jacket	Black Thermoplastic Elastomer	0.405	(10.29)	

LMR[®]-400-UF UltraFlex Communications Coax



Connectors

Interface	Description	Part Number	Stock Code	VSWR** Freq. (GHz)	Coupling Nut	Inner Contact Attach	Outer Contact Attach	Finish* Body /Pin	Length in (mm)	Width in (mm)	Weight lb (g)
7-16 DIN Female	Straight Jack	TC-400-716-FC	3190-376	<1.25:1 (2.5)	NA	Solder	Clamp	S/S	1.6 (41)	1.13 (28.7)	0.281 (127.5)
7-16 DIN Male	Straight Plug	TC-400-716-MC	3190-279	<1.25:1 (2.5)	Hex	Solder	Clamp	S/S	1.4 (36)	1.40 (35.6)	0.268 (121.6)
BNC Male	Straight Plug	TC-400-BM	3190-318	<1.25:1 (2.5)	Knurl	Solder	Crimp	N/S	1.7 (43)	0.56 (14.2)	0.063 (28.6)
Mini-UHF	Straight Plug	TC-400-MUHF	3190-520	<1.25:1 (2.5)	Knurl	Solder	Crimp	N/G	1.1 (28)	0.50 (12.7)	0.020 (9.1)
N Female	Straight Jack	TC-400-NFC	3190-299	<1.25:1 (2.5)	NA	Solder	Clamp	N/S	1.6 (41)	0.75 (19.1)	0.119 (54.0)
N Male	Straight Plug	SC-400-NM	3190-1454	<1.25:1 (2.5)	Knurl	Solder	Crimp	N/G	1.5 (38)	0.75 (19.1)	0.090 (40.8)
	Straight Plug	TC-400-NM	3190-188	<1.25:1 (2.5)	Knurl	Solder	Crimp	N/G	1.5 (38)	0.75 (19.1)	0.090 (40.8)
	Straight Plug	TC-400-NMC	3190-277	<1.25:1 (2.5)	Knurl	Solder	Clamp	N/G	1.5 (38)	0.75 (19.1)	0.121 (54.9)
	Straight Plug	TC-400-NMH-D	3190-552	<1.25:1 (10)	Hex/Knurl	Solder	Crimp	A/G	1.5 (38)	0.89 (22.6)	0.113 (51.3)
	Right Angle	TC-400-NMH-RA	3190-422*	<1.35:1 (6)	Hex	Solder	Crimp	S/G	1.8 (46)	1.25 (31.8)	0.130 (59.0)
	Right Angle	TC-400-NMH-RA-D	3190-2293*	<1.35:1 (6)	Hex/Knurl	Solder	Crimp	A/G	1.8 (46)	1.25 (31.8)	0.130 (59.0)
SMA Male	Straight Plug	TC-400-SM	3190-439	<1.25:1 (8)	Hex	Solder	Crimp	N/G	1.2 (29)	0.50 (12.7)	0.032 (14.5)
TNC Male	Straight Plug	TC-400-TM	3190-260	<1.25:1 (2.5)	Knurl	Solder	Crimp	N/S	1.7 (43)	0.59 (15.0)	0.074 (33.6)
	Right Angle	TC-400-TM-RA	3190-442*	<1.35:1 (2.5)	Knurl	Solder	Crimp	N/G	1.7 (43)	0.59 (15.0)	0.085 (38.6)

* Finish metals: N=Nickel, S=Silver, G=Gold, SS=Stainless Steel, A=Alballoy **VSWR spec based on 3 foot cable with a connector pair *Available in bulk pack

MICROWAVE

Mechanical Specifications			
Performance Property	Units	US	(metric)
Bend Radius: installation	in. (mm)	1.0	(25.4)
Bend Radius: repeated	in. (mm)	4.0	(101.6)
Bending Moment	ft-lb (N-m)	0.375	(0.51)
Weight	lb/ft (kg/m)	.088	(0.131)
Tensile Strength	lb (kg)	160	(72.6)
Flat Plate Crush	lb/in. (kg/mm)	20	(0.36)

Environmental Specifications		
Performance Property	°F	°C
Installation Temperature Range	-40/+185	-40/+85
Storage Temperature Range	-94/+185	-70/+85
Operating Temperature Range	-40/+185	-40/+85

Electrical Specifications			
Performance Property	Units	US	(metric)
Cutoff Frequency	GHz		16.2
Velocity of Propagation	%		85
Dielectric Constant	NA		1.38
Time Delay	nS/ft (nS/m)	1.20	(3.92)
Impedance	ohms		50
Capacitance	pF/ft (pF/m)	23.9	(78.40)
Inductance	uH/ft (uH/m)	0.060	(0.21)
Shielding Effectiveness	dB		>90
DC Resistance			
Inner Conductor	ohms/1000ft (/km)	1.07	(3.51)
Outer Conductor	ohms/1000ft (/km)	1.65	(5.4)
Voltage Withstand	Volts DC		2500
Jacket Spark	Volts RMS		8000
Peak Power	kW		16

Attenuation vs. Frequency (typical)

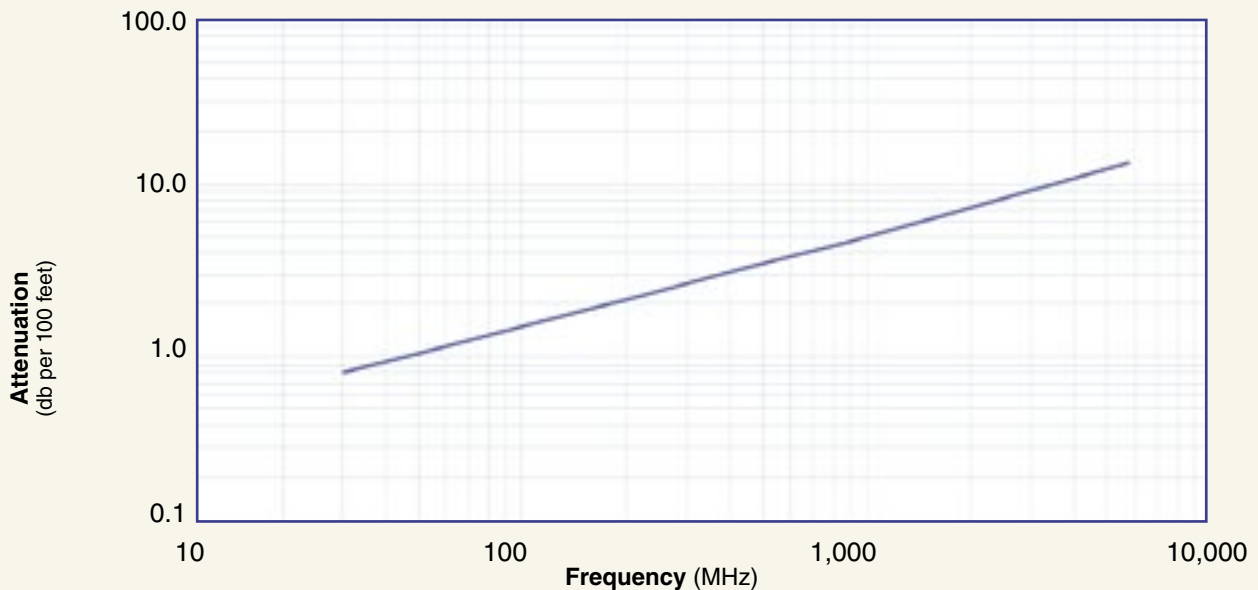

Frequency (MHz)	30	50	150	220	450	900	1500	1800	2000	2500	5800
Attenuation dB/100 ft	0.8	1.1	1.8	2.2	3.3	4.7	6.2	6.8	7.2	8.1	13.0
Attenuation dB/100 m	2.7	3.5	6.1	7.4	10.7	15.4	20.2	22.3	23.6	26.6	42.6
Avg. Power kW	2.77	2.14	1.22	1.00	0.69	0.48	0.36	0.33	0.31	0.28	0.17

Calculate Attenuation = $(0.146748) \cdot \sqrt{\text{FMHz}} + (0.000312) \cdot \text{FMHz}$ (interactive calculator available at http://www.timesmicrowave.com/cable_calculators)
 Attenuation: VSWR=1.0; Ambient = +25°C (77°F) Power: VSWR=1.0; Ambient = +40°C; Inner Conductor = 100°C (212°F);
 Sea Level; dry air; atmospheric pressure; no solar loading



Hardware Accessories

Type	Part Number	Stock Code	Description
Ground Kit	GK-S400TT	GK-S400TT	Standard Grounding Kit (each)
Hoisting Grip	HG-400T	HG-400T	Laced Type (each)



Install Tools

Type	Part Number	Stock Code	Description
Crimp Tool	HX-4	3190-200	Crimp Handle
Crimp Dies	Y1719	3190-202	.429" Hex Dies
Crimp Tool	CT-400/300	3190-666	Crimp tool for LMR 400 connectors
Crimp Rings	CR-400	3190-830	Crimp rings for TC/EZ-400 connectors (package of 10)
Cutting Tool	CCT-01	3190-1544	Cable end flush cut tool
Replacement Blade	RB-01	3190-1609	Replacement blade for cutting tool