



Fire Rated SMA Male to SMA Male Low Loss
Cable Using LMR-200-FR Coax

RF Cable Assemblies Technical Data Sheet

PE3W12072

Configuration

- Connector 1: SMA Male
- Connector 2: SMA Male
- Cable Type: LMR-200-FR

Features

- Shielding Effectivity > 90 dB
- 83% Phase Velocity
- Double Shielded
- FRPE Jacket

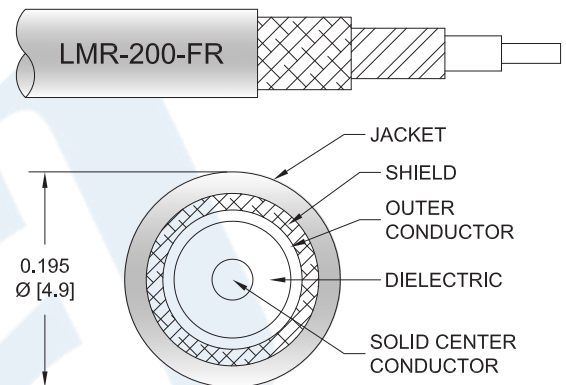

Applications

- General Purpose
- Laboratory Use

Description

Pasternack's PE3W12072 SMA male to SMA male cable using LMR-200-FR coax is part of our full line of RF components available for same-day shipping. Pasternack's flexible RF cable assemblies are ideal for applications where tight bends and flexure are required. This Pasternack SMA to SMA cable assembly has a male to male gender configuration with 50 ohm flexible LMR-200-FR coax. The double shielding of this Pasternack cable assembly provides excellent shielding effectiveness of better than 90 dB.

Custom versions of most RF cable assemblies can be built and shipped same day. Custom cable assembly lengths can be obtained by specifying the desired length on the web site at time of order or by contacting a sales representative. Other available RF cable assembly value added services include connector orientation or clocking, heat shrink booting and custom labeling. RF testing can also be performed to document the electrical performance of your cable assembly.

Electrical Specifications

Description	Minimum	Typical	Maximum	Units
Velocity of Propagation		83		%
RF Shielding	90			dB
Group Delay		1.22 [4]		ns/ft [ns/m]
Capacitance		24.5 [80.38]		pF/ft [pF/m]
Inductance		0.061 [0.2]		uH/ft [uH/m]
DC Resistance Inner Conductor		5.36 [17.59]		Ω/1000ft [Ω/Km]
DC Resistance Outer Conductor		4.9 [16.08]		Ω/1000ft [Ω/Km]
Jacket Spark			3,000	Vrms

Click the following link (or enter part number in "SEARCH" on website) to obtain additional part information including price, inventory and certifications: [Fire Rated SMA Male to SMA Male Low Loss Cable Using LMR-200-FR Coax PE3W12072](#)



Fire Rated SMA Male to SMA Male Low Loss
Cable Using LMR-200-FR Coax

RF Cable Assemblies Technical Data Sheet

PE3W12072

Mechanical Specifications

Cable Assembly

Weight 0.054 lbs [24.49 g]

Cable

Cable Type LMR-200-FR
 Impedance 50 Ohms
 Inner Conductor Type Solid
 Inner Conductor Material and Plating Copper
 Dielectric Type PE
 Number of Shields 2
 Shield Layer 1 Aluminum Tape
 Shield Layer 2 Tinned Copper Braid
 Jacket Material FRPE, Black
 Jacket Diameter 0.195 in [4.95 mm]

One Time Minimum Bend Radius 0.5 in [12.7 mm]
 Repeated Minimum Bend Radius 2 in [50.8 mm]
 Bending Moment 2 lbs-ft [2.71 N-m]
 Flat Plate Crush 15 lbs/in [0.27 Kg/mm]
 Tensile Strength 40 lbs [18.14 Kg]

Connectors

Description	Connector 1	Connector 2
Type	SMA Male	SMA Male
Impedance	50 Ohms	50 Ohms
Contact Material and Plating	Brass, Gold	Brass, Gold
Dielectric Type	Teflon	Teflon
Body Material and Plating	Brass, Gold	Brass, Gold
Coupling Nut Material and Plating	Brass, Gold	Brass, Gold
Hex Size	5/16 Inch	5/16 Inch

Compliance Certifications (see [product page](#) for current document)

Plotted and Other Data

Notes:

Click the following link (or enter part number in "SEARCH" on website) to obtain additional part information including price, inventory and certifications: [Fire Rated SMA Male to SMA Male Low Loss Cable Using LMR-200-FR Coax PE3W12072](#)



Fire Rated SMA Male to SMA Male Low Loss Cable Using LMR-200-FR Coax

RF Cable Assemblies Technical Data Sheet

PE3W12072

How to Order

Part Number Configuration:

PE3W12072

- **xx**

uu

Unit of Measure:

cm = Centimeters

<blank> = Inches

Length

Base Number

Example: PE3W12072-12 = 12 inches long cable
PE3W12072-100cm = 100 cm long cable

Fire Rated SMA Male to SMA Male Low Loss Cable Using LMR-200-FR Coax from Pasternack Enterprises has same day shipment for domestic and International orders. Our RF, microwave and millimeter wave products maintain a 99.4% availability and are part of the broadest selection in the industry.

Click the following link (or enter part number in "SEARCH" on website) to obtain additional part information including price, inventory and certifications: [Fire Rated SMA Male to SMA Male Low Loss Cable Using LMR-200-FR Coax PE3W12072](https://www.pasternack.com/fire-rated-sma-male-to-sma-male-low-loss-cable-using-lmr-200-fr-pe3w12072-p.aspx)

URL: <https://www.pasternack.com/fire-rated-sma-male-to-sma-male-low-loss-cable-using-lmr-200-fr-pe3w12072-p.aspx>

The information contained in this document is accurate to the best of our knowledge and representative of the part described herein. It may be necessary to make modifications to the part and/or the documentation of the part, in order to implement improvements. Pasternack reserves the right to make such changes as required. Unless otherwise stated, all specifications are nominal. Pasternack does not make any representation or warranty regarding the suitability of the part described herein for any particular purpose, and Pasternack does not assume any liability arising out of the use of any part or documentation.

PE3W12072 CAD Drawing

Fire Rated SMA Male to SMA Male Low Loss Cable Using LMR-200-FR Coax

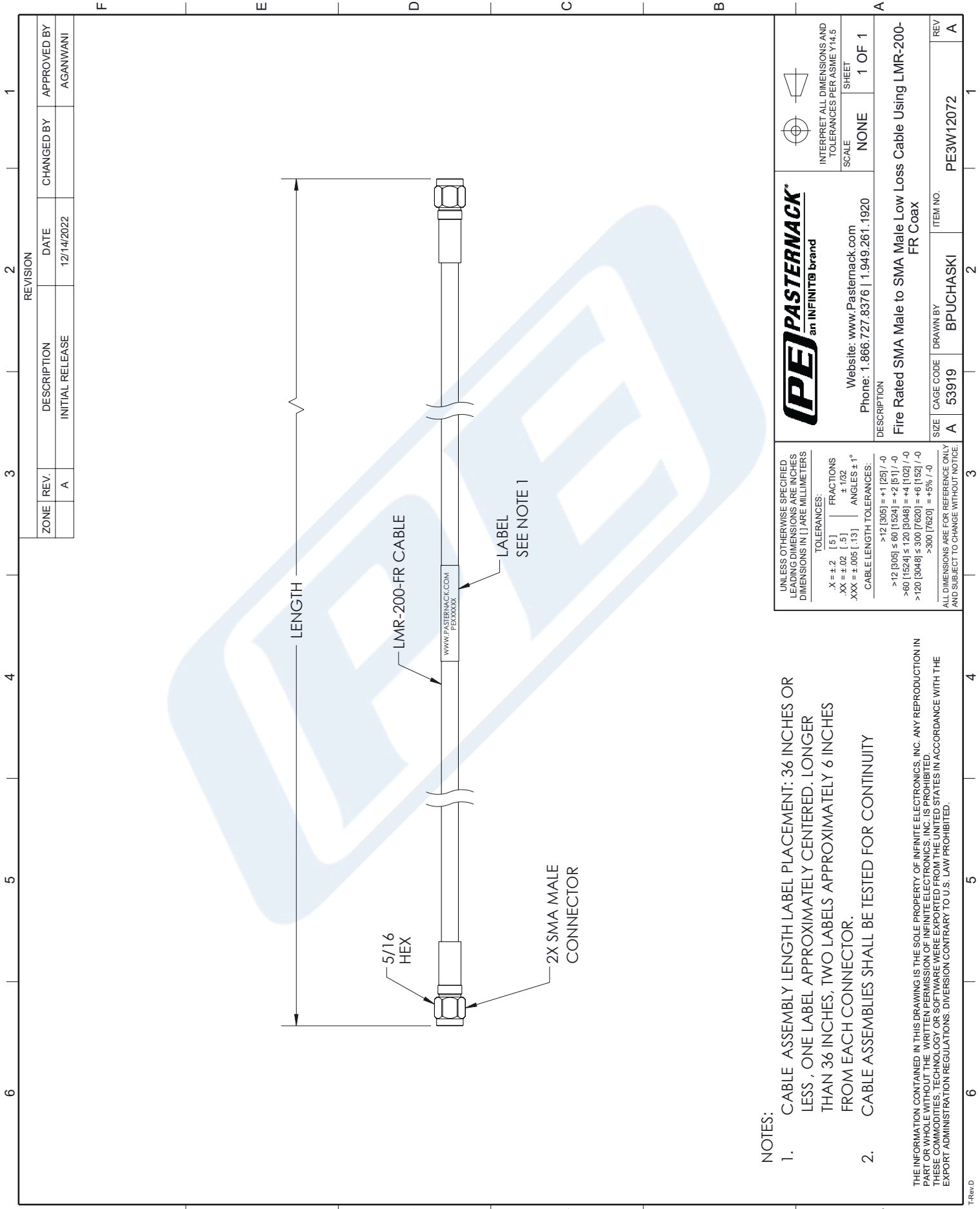



NOTES:

1. CABLE ASSEMBLY LENGTH LABEL PLACEMENT: 36 INCHES OR LESS, ONE LABEL APPROXIMATELY CENTERED. LONGER THAN 36 INCHES, TWO LABELS APPROXIMATELY 6 INCHES FROM EACH CONNECTOR.
2. CABLE ASSEMBLIES SHALL BE TESTED FOR CONTINUITY

THE INFORMATION CONTAINED IN THIS DRAWING IS THE SOLE PROPERTY OF INFINITE ELECTRONICS, INC. ANY REPRODUCTION IN PART OR WHOLE WITHOUT THE WRITTEN PERMISSION OF INFINITE ELECTRONICS, INC. IS PROHIBITED. THESE COMMODITIES, TECHNOLOGY OR SOFTWARE WERE EXPORTED FROM THE UNITED STATES IN ACCORDANCE WITH THE EXPORT ADMINISTRATION REGULATIONS. DIVERSION CONTRARY TO U.S. LAW PROHIBITED.

UNLESS OTHERWISE SPECIFIED LEADING DIMENSIONS ARE INCHES DIMENSIONS IN [] ARE MILLIMETERS	
TOLERANCES:	
.X = ±.2 [.5]	FRACTIONS ± 1/32
.XX = ±.02 [.1]	ANGLES ± 1°
.XXX = ±.005 [.13]	CABLE LENGTH TOLERANCES:
	>12 [305] = +1 [25] / -0
	>60 [1524] = +2 [51] / -0
	>120 [3048] = +4 [102] / -0
	>300 [7620] = +6 [152] / -0
	>500 [12700] = +5% / -0
ALL DIMENSIONS ARE FOR REFERENCE ONLY AND SUBJECT TO CHANGE WITHOUT NOTICE.	

PE PASTERNAK an INFINITO brand		 
Website: www.Pasternack.com Phone: 1.866.727.8376 1.949.261.1920		INTERPRET ALL DIMENSIONS AND TOLERANCES PER ASME Y14.5
DESCRIPTION Fire Rated SMA Male to SMA Male Low Loss Cable Using LMR-200-FR Coax		SCALE NONE
SIZE A		SHEET 1 OF 1
DRAWN BY BPUCHASKI		REV A
ITEM NO. PE3W12072		