

Reverse Polarity TNC Jack Bulkhead to Reverse Polarity SMA Plug Low Loss Cable Using LMR-100 Coax



PE3W13300

Configuration

- Connector 1: TNC Jack Reverse Polarity Bulkhead
- Connector 2: SMA Plug Reverse Polarity
- Cable Type: LMR-100A
- Coax Flex Type: Flexible

Features

- Max Frequency 3 GHz
- Shielding Effectivity > 90 dB
- 66% Phase Velocity
- Double Shielded
- PVC Jacket



Applications

- General Purpose
- Laboratory Use

Description

Pasternack's PE3W13300 reverse polarity TNC jack bulkhead to reverse polarity SMA plug cable using LMR-100 coax is part of our full line of RF components available for same-day shipping. Pasternack's flexible RF cable assemblies are ideal for applications where tight bends and flexure are required. This Pasternack reverse polarity TNC to reverse polarity SMA cable assembly has a jack to plug gender configuration with 50 ohm flexible LMR-100A coax. The PE3W13300 reverse polarity TNC jack to reverse polarity SMA plug cable assembly operates to 3 GHz. Our RF cable assembly with TNC bulkhead interface allows designers to create external connections on their product enclosures, and can be used in a variety of other rack mount and panel mount applications. The double shielding of this Pasternack cable assembly provides excellent shielding effectiveness of better than 90 dB.

Custom versions of most RF cable assemblies can be built and shipped same day. Custom cable assembly lengths can be obtained by specifying the desired length on the web site at time of order or by contacting a sales representative. Other available RF cable assembly value added services include connector orientation or clocking, heat shrink booting and custom labeling. RF testing can also be performed to document the electrical performance of your cable assembly.

Electrical Specifications

Description	Minimum	Typical	Maximum	Units
Frequency Range	DC		3	GHz
Velocity of Propagation		66		%
RF Shielding	90			dB
Group Delay		1.54 [5.05]		ns/ft [ns/m]
Capacitance		30.8 [101.05]		pF/ft [pF/m]
Inductance		0.077 [0.25]		uH/ft [uH/m]
DC Resistance Inner Conductor		81 [265.75]		Ohms/1000ft [Ohms/Km]
DC Resistance Outer Conductor		9.5 [31.17]		Ohms/1000ft [Ohms/Km]

Reverse Polarity TNC Jack Bulkhead to Reverse Polarity SMA Plug Low Loss Cable Using LMR-100 Coax



PE3W13300

Electrical Specifications

Description	Minimum	Typical	Maximum	Units
Jacket Spark			2,000	Vrms

Specifications by Frequency

Part Number	Length	Description	F1	F2	F3	F4	F5	Units	Weight (lbs)
			Frequency					MHz	
PE3W13300	Custom Lengths Available	Insertion Loss (Typ.)	0.064	0.115	0.165	0.24	0.432	dB/ft	
			0.21	0.38	0.55	0.79	1.42	dB/m	
PE3W13300-24	24 In	Insertion Loss (Typ.)	0.33	0.43	0.53	0.68	1.07	dB	0.064
PE3W13300-36	36 In	Insertion Loss (Typ.)	0.4	0.55	0.7	0.92	1.5	dB	0.073
PE3W13300-48	48 In	Insertion Loss (Typ.)	0.46	0.66	0.86	1.16	1.93	dB	0.082
PE3W13300-100CM	100 CM	Insertion Loss (Typ.)	0.41	0.58	0.75	0.99	1.62	dB	0.076
PE3W13300-200CM	200 CM	Insertion Loss (Typ.)	0.62	0.96	1.29	1.78	3.04	dB	0.106

The insertion loss data for the base model does not include loss due to the connectors. Each length includes insertion loss due to the connectors.

Loss due to Connector 1:	0.1 dB
Loss due to Connector 2:	0.1 dB
Base Weight:	0.055 pounds
Additional Weight per Inch:	0.00075 pounds

Mechanical Specifications

Cable Assembly

Width/Diameter	0.5 in [12.7 mm]
Weight	0.055 lbs [24.95 g]

Cable

Cable Type	LMR-100A
Impedance	50 Ohms
Inner Conductor Type	Solid
Inner Conductor Material and Plating	Copper Clad Steel
Dielectric Type	PE
Number of Shields	2
Shield Layer 1	Aluminum Tape
Shield Layer 2	Tinned Copper Braid
Jacket Material	PVC, Black
Jacket Diameter	0.11 in [2.79 mm]
One Time Minimum Bend Radius	0.25 in [6.35 mm]
Repeated Minimum Bend Radius	1 in [25.4 mm]
Bending Moment	0.1 lbs-ft [0.14 N-m]
Flat Plate Crush	10 lbs/in [0.18 Kg/mm]
Tensile Strength	15 lbs [6.8 Kg]

Reverse Polarity TNC Jack Bulkhead to Reverse Polarity SMA Plug Low Loss Cable Using LMR-100 Coax



PE3W13300

Connectors

Description	Connector 1	Connector 2
Type	TNC Jack Reverse Polarity Bulkhead	SMA Plug Reverse Polarity
Specification		MIL-STD-348
Impedance	50 Ohms	50 Ohms
Configuration	Straight	Straight
Contact Material and Plating	Phosphor Bronze, Gold	Gold
Contact Plating Specification	30 µin minimum	MIL-G-45204
Dielectric Type	PTFE	PTFE
Body Material and Plating	Brass, Nickel	Brass, Nickel
Body Plating Specification		QQ-N-290
Coupling Nut Material and Plating		Brass, Nickel
Coupling Nut Plating Specification		QQ-N-290
Hex Size		5/16 inch
Torque		3 in-lbs 0.34 Nm

Environmental Specifications

Compliance Certifications (see [product page](#) for current document)

Plotted and Other Data

Notes:

Reverse Polarity TNC Jack Bulkhead to Reverse Polarity SMA Plug Low Loss Cable Using LMR-100 Coax



PE3W13300

Typical Performance Data

How to Order

Part Number Configuration:

PE3W13300

- **xx**

uu

Unit of Measure:

cm = Centimeters

<blank> = Inches

Length

Base Number

Example: PE3W13300-12 = 12 inches long cable
PE3W13300-100cm = 100 cm long cable

Reverse Polarity TNC Jack Bulkhead to Reverse Polarity SMA Plug Low Loss Cable Using LMR-100 Coax from Pasternack Enterprises has same day shipment for domestic and International orders. Our RF, microwave and millimeter wave products maintain a 99.4% availability and are part of the broadest selection in the industry.

Click the following link (or enter part number in "SEARCH" on website) to obtain additional part information including price, inventory and certifications: [Reverse Polarity TNC Jack Bulkhead to Reverse Polarity SMA Plug Low Loss Cable Using LMR-100 Coax PE3W13300](https://www.pasternack.com/reverse-polarity-tnc-jack-bulkhead-to-reverse-polarity-sma-plug-low-loss-cable-using-lmr-100-pe3w13300-p.aspx)

URL: <https://www.pasternack.com/reverse-polarity-tnc-jack-bulkhead-to-reverse-polarity-sma-plug-low-loss-cable-using-lmr-100-pe3w13300-p.aspx>

The information contained within this document is accurate to the best of our knowledge and representative of the part described herein. It may be necessary to make modifications to the part and/or the documentation of the part in order to impliment improvements. Pasternack Enterprises reserves the right to make such changes as required. Unless otherwise stated, all specifications are nominal. Pasternack Enterprises does not make any representation or warranty regarding the suitability of the part described herein for any particular purpose, and Pasternack Enterprises does not assume liability arising out of the use of any part or document.

PE3W13300 CAD Drawing

Reverse Polarity TNC Jack Bulkhead to Reverse Polarity SMA Plug Low Loss Cable Using LMR-100 Coax

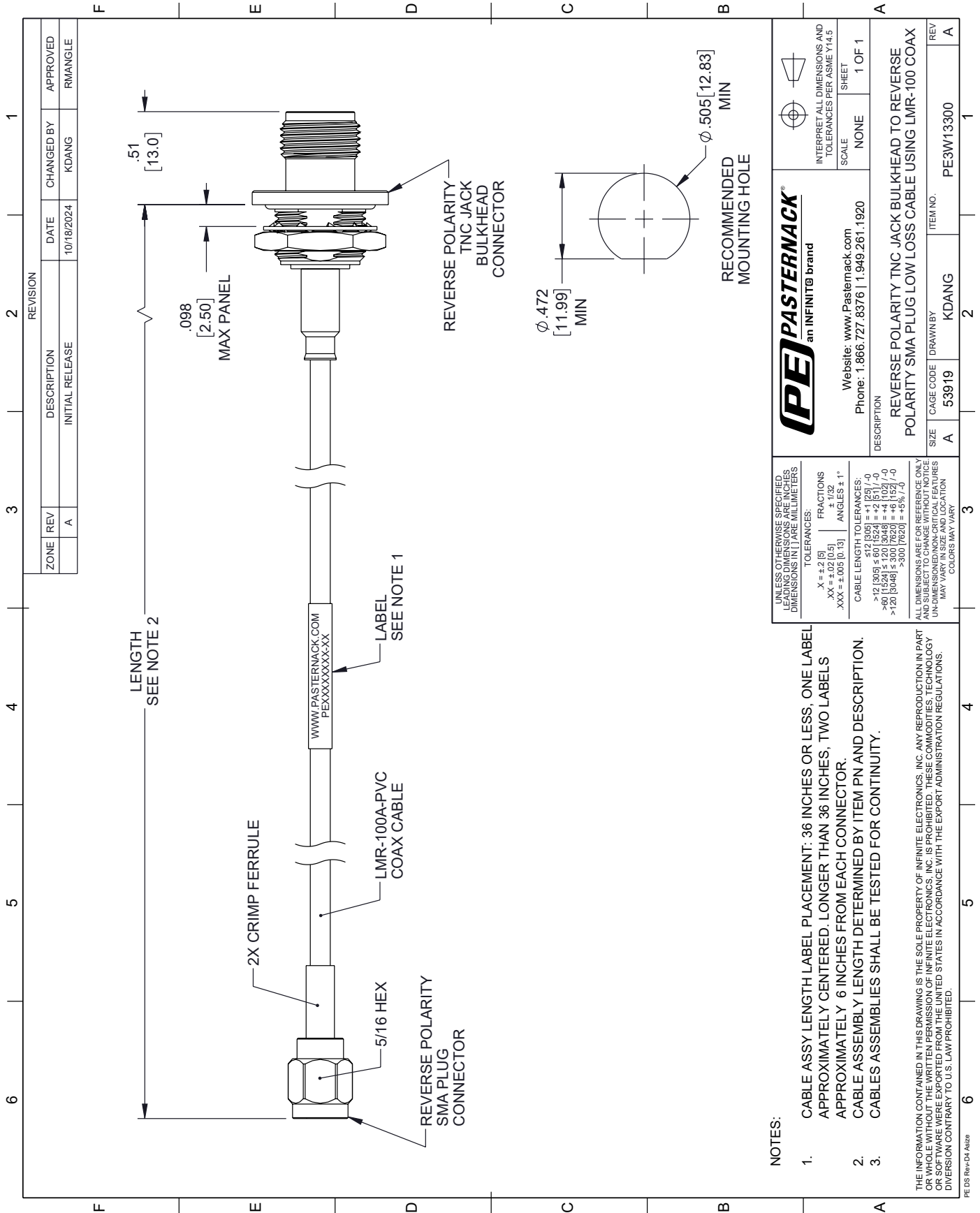

UNLESS OTHERWISE SPECIFIED LEADING DIMENSIONS ARE INCHES DIMENSIONS IN PARENS ARE MILLIMETERS				
TOLERANCES:	CABLE LENGTH TOLERANCES: >12 (305) ≤ 60 (1524) = +1 (25) / -0 >60 (1524) ≤ 120 (3048) = +4 (102) / -0 >120 (3048) ≤ 300 (7620) = +5 (127) / -0 >300 (7620) = +5 (127) / -0			
ALL DIMENSIONS ARE FOR REFERENCE ONLY UNLESS OTHERWISE SPECIFIED. DIMENSIONS UNLESS OTHERWISE SPECIFIED ARE IN INCHES AND DECIMAL FRACTIONS UNLESS OTHERWISE SPECIFIED. DIMENSIONS IN PARENS ARE IN MILLIMETERS. DIMENSIONS MAY VARY IN SIZE AND LOCATION. COLORS MAY VARY.				

		Website: www.Pasternack.com Phone: 1.866.727.8376 1.949.261.1920	
INTERPRET ALL DIMENSIONS AND TOLERANCES PER ASME Y14.5		SCALE	NONE
SHEET		1 OF 1	
DESCRIPTION REVERSE POLARITY TNC JACK BULKHEAD TO REVERSE POLARITY SMA PLUG LOW LOSS CABLE USING LMR-100 COAX			
REV	DATE	CHANGED BY	APPROVED
A	10/18/2024	KDANG	RWANGLE
ZONE	REV	DESCRIPTION	DATE
	A	INITIAL RELEASE	

SIZE	CAGE CODE	DRAWN BY	ITEM NO.
A	53919	KDANG	PE3W13300

NOTES:

- CABLE ASSY LENGTH LABEL PLACEMENT: 36 INCHES OR LESS, ONE LABEL APPROXIMATELY CENTERED. LONGER THAN 36 INCHES, TWO LABELS APPROXIMATELY 6 INCHES FROM EACH CONNECTOR.
- CABLE ASSEMBLY LENGTH DETERMINED BY ITEM PN AND DESCRIPTION.
- CABLES ASSEMBLIES SHALL BE TESTED FOR CONTINUITY.

THE INFORMATION CONTAINED IN THIS DRAWING IS THE SOLE PROPERTY OF INFINITE ELECTRONICS, INC. ANY REPRODUCTION IN PART OR WHOLE WITHOUT THE WRITTEN PERMISSION OF INFINITE ELECTRONICS, INC. IS PROHIBITED. THESE COMMODITIES, TECHNOLOGY OR SOFTWARE WERE EXPORTED FROM THE UNITED STATES IN ACCORDANCE WITH THE EXPORT ADMINISTRATION REGULATIONS. DIVERSION CONTRARY TO U.S. LAW PROHIBITED.