



# QMA Male Right Angle Connector Solder Attachment for PE-SR402AL, PE-SR402FL, PE-SR402FLJ, PE-SR402TN, RG402

## RF Connectors Technical Data Sheet

PE44498

### Configuration

- QMA Male Connector
- 50 Ohms
- Right Angle Body Geometry
- PE-SR402AL, PE-SR402FL, PE-SR402FLJ, PE-SR402TN, RG402 Interface Type
- Solder/Solder Attachment

### Features

- Max. Operating Frequency 18 GHz
- PIM levels lower than -130 dBc
- Gold over Nickel Plated Brass Contact
- 0.15  $\mu\text{m}$  minimum contact plating

### Applications

- General Purpose Test
- Custom Cable Assemblies

### Description

Pasternack's PE44498 QMA male right angle connector with solder/solder attachment for PE-SR402AL, PE-SR402FL, PE-SR402FLJ, PE-SR402TN and RG402 is part of our full line of RF components available for same-day shipping. Our QMA male connector operates up to a maximum frequency of 18 GHz. The QMA male connector also has low passive intermodulation of -130 dBc. Its right angle body geometry allows for easier connections in tight spaces.

Our QMA male right angle connector PE44498 datasheet specifications and drawing with dimensions are shown below in this PDF. Pasternack's broad catalog of RF, microwave and millimeter wave connectors allows designers to configure and customize their signal connections however they like. Whether the need is to provide an I/O for a board design, or simply create a custom cable assembly configuration, Pasternack has the right connector for the job. Pasternack can also expertly build your custom cable assemblies for you and ship same-day.

### Electrical Specifications

Description	Minimum	Typical	Maximum	Units
Frequency Range	DC		18	GHz
Passive Intermodulation using 2x20W tones			-130	dBc
Operating Voltage (AC)			335	Vrms
Test Voltage (AC)			1,000	Vrms
Inner Conductor DC Resistance			3	mOhms
Outer Conductor DC Resistance			2.5	mOhms
Insulation Resistance	5,000			MOhms

Click the following link (or enter part number in "SEARCH" on website) to obtain additional part information including price, inventory and certifications: [QMA Male Right Angle Connector Solder Attachment for PE-SR402AL, PE-SR402FL, PE-SR402FLJ, PE-SR402TN, RG402 PE44498](#)



QMA Male Right Angle Connector Solder Attachment for PE-SR402AL, PE-SR402FL, PE-SR402FLJ, PE-SR402TN, RG402

## RF Connectors Technical Data Sheet

PE44498

### Performance by Frequency

Description	F1	F2	F3	F4	F5	Units
Frequency Range	DC to 3	3 to 4	4 to 6			GHz
VSWR, Max	1.06:1	1.09:1	1.12:1			

### Electrical Specification Notes:

RF leakage: 95 dB (up to 2 GHz), 80 dB (up to 4 GHz), 70 dB (up to 6 GHz) min.  
 Insertion loss = 0.05 x sqrt(fGHz) dB max up to 6 GHz.

### Mechanical Specifications

#### Size

Length	0.713 in [18.11 mm]
Width/Dia.	0.413 in [10.49 mm]
Height	0.496 in [12.6 mm]
Weight	0.006 lbs [2.72 g]
Mating Cycles	100 Cycles

### Material Specifications

Description	Material	Plating
Contact	Brass	Gold over Nickel 0.15 µm minimum
Insulation	PTFE	
Outer Conductor	Spring Bronze	Tri-Metal
Body	Brass	Gold 0.15 µm minimum

### Environmental Specifications

#### Temperature

Operating Range	-40 to +85 deg C
Storage Range	-40 to +85 deg C

Humidity	IEC 60169-1 16.3 (96 hours)
Vibration	IEC 60068-2-64 random
Thermal Shock	IEC 60169-1 16.4 (-40/+85°C)
Salt Spray	IEC 60109-1 16.7 (48 hrs)

Click the following link (or enter part number in "SEARCH" on website) to obtain additional part information including price, inventory and certifications: [QMA Male Right Angle Connector Solder Attachment for PE-SR402AL, PE-SR402FL, PE-SR402FLJ, PE-SR402TN, RG402 PE44498](#)



QMA Male Right Angle Connector Solder Attachment for PE-SR402AL, PE-SR402FL, PE-SR402FLJ, PE-SR402TN, RG402

## RF Connectors Technical Data Sheet

PE44498

**Compliance Certifications** (see [product page](#) for current document)

### Plotted and Other Data

Notes:

QMA Male Right Angle Connector Solder Attachment for PE-SR402AL, PE-SR402FL, PE-SR402FLJ, PE-SR402TN, RG402 from Pasternack Enterprises has same day shipment for domestic and International orders. Our RF, microwave and millimeter wave products maintain a 99% availability and are part of the broadest selection in the industry.

Click the following link (or enter part number in "SEARCH" on website) to obtain additional part information including price, inventory and certifications: [QMA Male Right Angle Connector Solder Attachment for PE-SR402AL, PE-SR402FL, PE-SR402FLJ, PE-SR402TN, RG402 PE44498](#)

URL: <https://www.pasternack.com/qma-male-standard-pe-sr402al-pe-sr402fl-rg402-connector-pe44498-p.aspx>

The information contained in this document is accurate to the best of our knowledge and representative of the part described herein. It may be necessary to make modifications to the part and/or the documentation of the part, in order to implement improvements. Pasternack reserves the right to make such changes as required. Unless otherwise stated, all specifications are nominal. Pasternack does not make any representation or warranty regarding the suitability of the part described herein for any particular purpose, and Pasternack does not assume any liability arising out of the use of any part or documentation.

# PE44498 CAD Drawing

QMA Male Right Angle Connector Solder Attachment for PE-SR402AL,  
PE-SR402FL, PE-SR402FLJ, PE-SR402TN, RG402

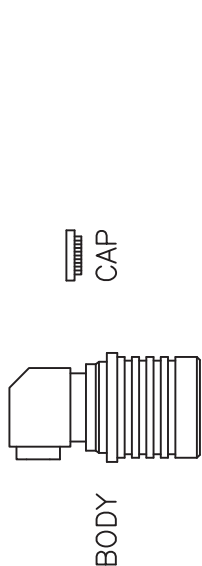

### ASSEMBLY PROCEDURES

1. STRIP CABLE AS SHOWN & TIN CENTER CONDUCTOR.

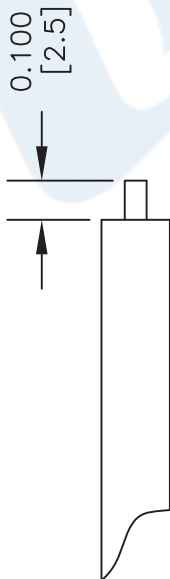

2. SOLDER INNER CONDUCTOR TO THE CONTACT OF BODY AND SOLDER SHIELD TO THE BODY AS SHOWN.

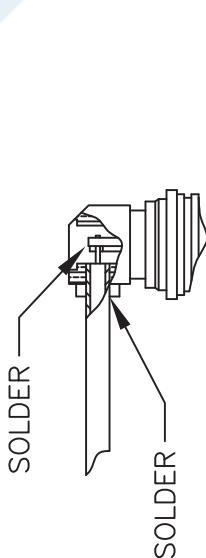

3. PRESS CAP DOWN.

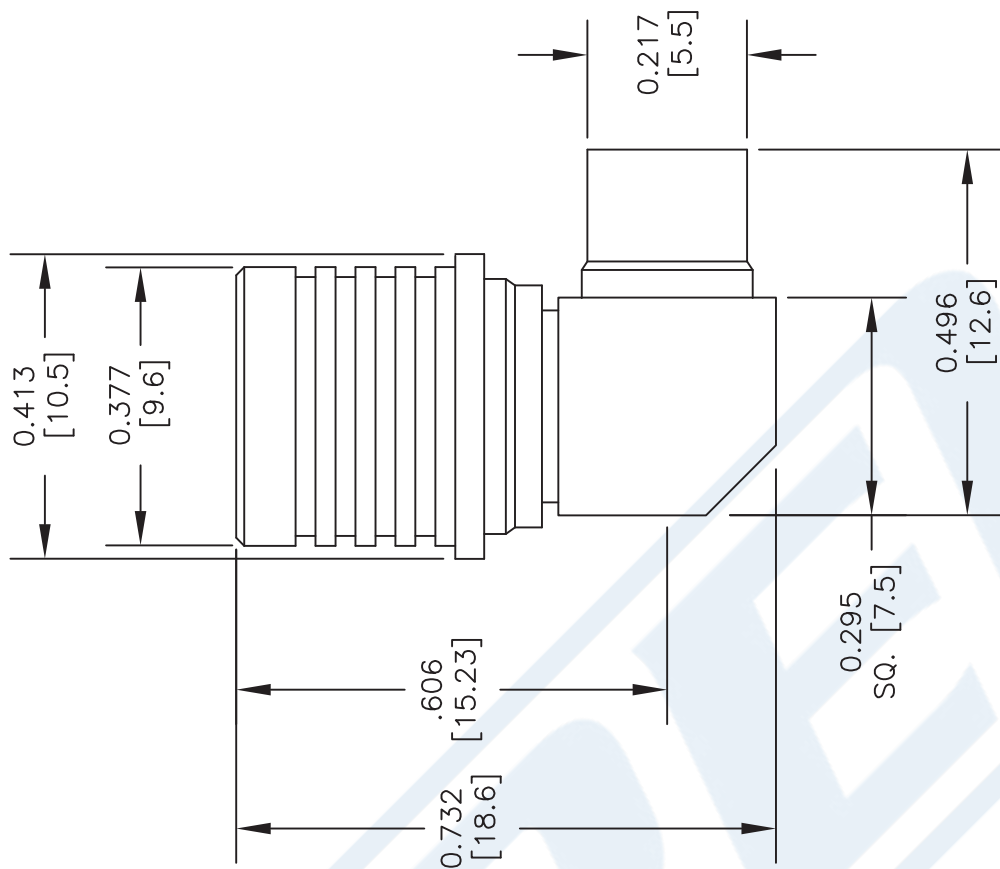
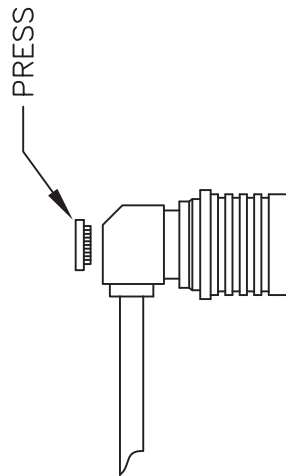

DWG TITLE

**PE44498**

NOTES:  
1. UNLESS OTHERWISE SPECIFIED ALL DIMENSIONS ARE NOMINAL.  
2. ALL SPECIFICATIONS ARE SUBJECT TO CHANGE WITHOUT NOTICE AT ANY TIME.  
3. DIMENSIONS ARE IN INCHES [mm].  
4. FITS MIL-C-17 AND EQUIVALENT CABLES.

FSCM NO. 53919

CAD FILE 083013

SCALE N/A

SIZE A

2233

**PE PASTERNAK®**

Pasternack Enterprises, Inc.  
P.O. Box 16759 | Irvine | CA | 92623  
Phone: (949) 261-1920 | Fax: (949) 261-7451  
Website: www.pasternack.com | E-Mail: sales@pasternack.com



QMA Male Right Angle Connector Solder Attachment for PE-SR402AL, PE-SR402FL, PE-SR402FLJ, PE-SR402TN, RG402

RF Connectors Technical Data Sheet

PE44498

**Configuration**

- QMA Male Connector
- 50 Ohms
- Right Angle Body Geometry
- PE-SR402AL, PE-SR402FL, PE-SR402FLJ, PE-SR402TN, RG402 Interface Type
- Solder/Solder Attachment

**Features**

- Max. Operating Frequency 18 GHz
- PIM levels lower than -130 dBc
- Gold over Nickel Plated Brass Contact
- 0.15 µm minimum contact plating

**Applications**

- General Purpose Test
- Custom Cable Assemblies

**Description**

Pasternack's PE44498 QMA male right angle connector with solder/solder attachment for PE-SR402AL, PE-SR402FL, PE-SR402FLJ, PE-SR402TN and RG402 is part of our full line of RF components available for same-day shipping. Our QMA male connector operates up to a maximum frequency of 18 GHz. The QMA male connector also has low passive intermodulation of -130 dBc. Its right angle body geometry allows for easier connections in tight spaces.

Our QMA male right angle connector PE44498 datasheet specifications and drawing with dimensions are shown below in this PDF. Pasternack's broad catalog of RF, microwave and millimeter wave connectors allows designers to configure and customize their signal connections however they like. Whether the need is to provide an I/O for a board design, or simply create a custom cable assembly configuration, Pasternack has the right connector for the job. Pasternack can also expertly build your custom cable assemblies for you and ship same-day.

**Electrical Specifications**

Description	Minimum	Typical	Maximum	Units
Frequency Range	DC		18	GHz
Passive Intermodulation using 2x20W tones			-130	dBc
Operating Voltage (AC)			335	Vrms
Test Voltage (AC)			1,000	Vrms
Inner Conductor DC Resistance			3	mOhms
Outer Conductor DC Resistance			2.5	mOhms
Insulation Resistance	5,000			MOhms

Click the following link (or enter part number in "SEARCH" on website) to obtain additional part information including price, inventory and certifications: [QMA Male Right Angle Connector Solder Attachment for PE-SR402AL, PE-SR402FL, PE-SR402FLJ, PE-SR402TN, RG402 PE44498](#)



QMA Male Right Angle Connector Solder Attachment for PE-SR402AL, PE-SR402FL, PE-SR402FLJ, PE-SR402TN, RG402

## RF Connectors Technical Data Sheet

PE44498

### Performance by Frequency

Description	F1	F2	F3	F4	F5	Units
Frequency Range	DC to 3	3 to 4	4 to 6			GHz
VSWR, Max	1.06:1	1.09:1	1.12:1			

### Electrical Specification Notes:

RF leakage: 95 dB (up to 2 GHz), 80 dB (up to 4 GHz), 70 dB (up to 6 GHz) min.  
 Insertion loss = 0.05 x sqrt(fGHz) dB max up to 6 GHz.

### Mechanical Specifications

#### Size

Length	0.713 in [18.11 mm]
Width/Dia.	0.413 in [10.49 mm]
Height	0.496 in [12.6 mm]
Weight	0.006 lbs [2.72 g]
Mating Cycles	100 Cycles

### Material Specifications

Description	Material	Plating
Contact	Brass	Gold over Nickel 0.15 µm minimum
Insulation	PTFE	
Outer Conductor	Spring Bronze	Tri-Metal
Body	Brass	Gold 0.15 µm minimum

### Environmental Specifications

#### Temperature

Operating Range	-40 to +85 deg C
Storage Range	-40 to +85 deg C

Humidity	IEC 60169-1 16.3 (96 hours)
Vibration	IEC 60068-2-64 random
Thermal Shock	IEC 60169-1 16.4 (-40/+85°C)
Salt Spray	IEC 60109-1 16.7 (48 hrs)

Click the following link (or enter part number in "SEARCH" on website) to obtain additional part information including price, inventory and certifications: [QMA Male Right Angle Connector Solder Attachment for PE-SR402AL, PE-SR402FL, PE-SR402FLJ, PE-SR402TN, RG402 PE44498](#)



QMA Male Right Angle Connector Solder Attachment for PE-SR402AL, PE-SR402FL, PE-SR402FLJ, PE-SR402TN, RG402

## RF Connectors Technical Data Sheet

PE44498

**Compliance Certifications** (see [product page](#) for current document)

### Plotted and Other Data

Notes:

QMA Male Right Angle Connector Solder Attachment for PE-SR402AL, PE-SR402FL, PE-SR402FLJ, PE-SR402TN, RG402 from Pasternack Enterprises has same day shipment for domestic and International orders. Our RF, microwave and millimeter wave products maintain a 99% availability and are part of the broadest selection in the industry.

Click the following link (or enter part number in "SEARCH" on website) to obtain additional part information including price, inventory and certifications: [QMA Male Right Angle Connector Solder Attachment for PE-SR402AL, PE-SR402FL, PE-SR402FLJ, PE-SR402TN, RG402 PE44498](#)

URL: <https://www.pasternack.com/qma-male-standard-pe-sr402al-pe-sr402fl-rg402-connector-pe44498-p.aspx>

The information contained in this document is accurate to the best of our knowledge and representative of the part described herein. It may be necessary to make modifications to the part and/or the documentation of the part, in order to implement improvements. Pasternack reserves the right to make such changes as required. Unless otherwise stated, all specifications are nominal. Pasternack does not make any representation or warranty regarding the suitability of the part described herein for any particular purpose, and Pasternack does not assume any liability arising out of the use of any part or documentation.

# PE44498 CAD Drawing

QMA Male Right Angle Connector Solder Attachment for PE-SR402AL, PE-SR402FL, PE-SR402FLJ, PE-SR402TN, RG402

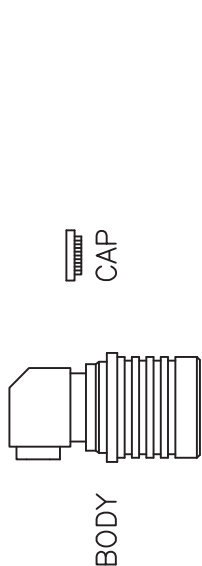

## ASSEMBLY PROCEDURES

1. STRIP CABLE AS SHOWN & TIN CENTER CONDUCTOR.

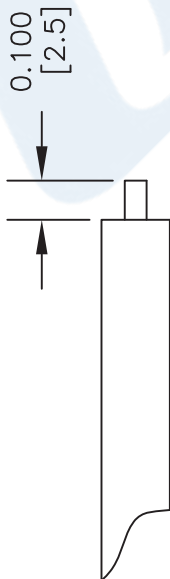

2. SOLDER INNER CONDUCTOR TO THE CONTACT OF BODY AND SOLDER SHIELD TO THE BODY AS SHOWN.

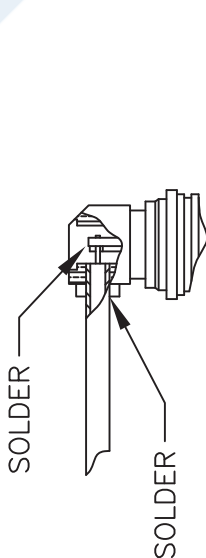

3. PRESS CAP DOWN.

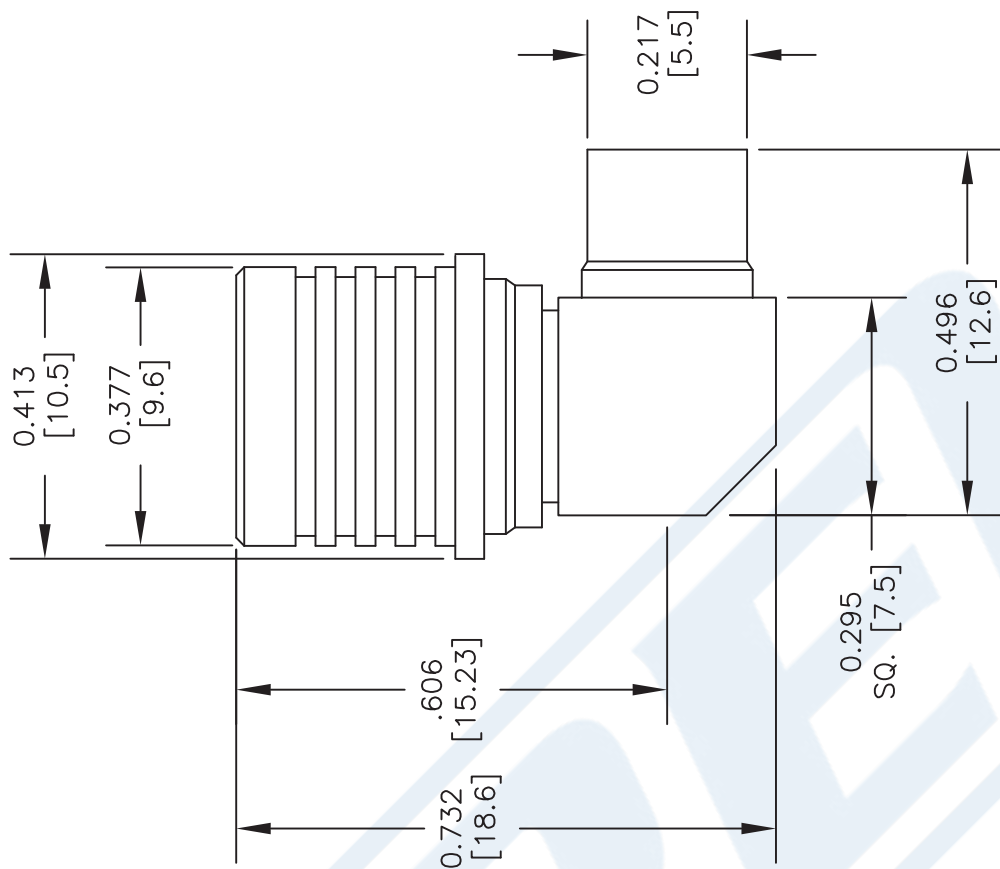
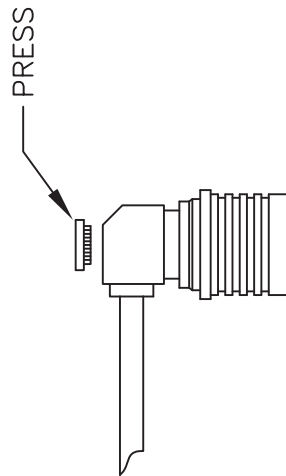

DWG TITLE

**PE44498**

NOTES:  
 1. UNLESS OTHERWISE SPECIFIED ALL DIMENSIONS ARE NOMINAL.  
 2. ALL SPECIFICATIONS ARE SUBJECT TO CHANGE WITHOUT NOTICE AT ANY TIME.  
 3. DIMENSIONS ARE IN INCHES [mm].  
 4. FITS MIL-C-17 AND EQUIVALENT CABLES.

FSCM NO. 53919

CAD FILE 083013

SCALE N/A

SIZE A

2233

**PE PASTERNAK®**

Pasternack Enterprises, Inc.  
 P.O. Box 16759 | Irvine | CA | 92623  
 Phone: (949) 261-1920 | Fax: (949) 261-7451  
 Website: www.pasternack.com | E-Mail: sales@pasternack.com



## Formable 141 Semirigid Coax Cable with Tinned Braid Outer Conductor and Black FEP Jacket

### RF Cables Technical Data Sheet

PE-SR402FLJ

#### Configuration

- Formable Cable

#### Features

- Dimensionally the same as standard solid outer conductor semi-rigid coax
- Standard semi-rigid connectors can be used
- Cable is hand formable and does not require special tools to bend
- Connectors are easily soldered to Tin soaked outer conductor
- Cable can be formed more than once without damage to outer conductor
- High RF Shielding >100 dB

#### Description

Formable semi-rigid coax is a hand formable version of standard semi-rigid that does not require complicated and costly pre-formed cable assemblies. Because the dimensions and electrical characteristics are so closely matched to semi-rigid coax, standard semi-rigid connectors can be used. The tin soaked copper braid outer shield provides excellent RF shielding. FEP Jacket reduces the chance of shorting exposed contacts or circuit conductors.

#### Electrical Specifications

Description	Minimum	Typical	Maximum	Units
Frequency Range	DC		34	GHz
Impedance		50		Ohms
Velocity of Propagation		70		%
Time Delay		1.43 4.69		ns/ft ns/m
Shielding Effectiveness	100			dB
Operating Voltage (AC)			1,900	Vrms
Dielectric Withstanding Voltage (AC)			3,000	Vrms
Inner Conductor DC Resistance			8.23	Ohms/1000ft
Nominal Capacitance		29 [95.14]		pF/ft [pF/m]
Insulation Resistance	1,524			MOhms/1000ft

#### Performance by Frequency Band

Description	F1	F2	F3	F4	F5	Units
Frequency	0.5	1	5	10	20	GHz
Attenuation, Typ	8.23	12.5	32	48.158	73.152	dB/100ft
	27	41.01	104.99	158	240	dB/100m
Input Power (CW), Max	436.5	303.4	126.7	85.5	56.6	Watts

Click the following link (or enter part number in "SEARCH" on website) to obtain additional part information including price, inventory and certifications: [Formable PE-SR402FLJ Coax Cable with Tinned Copper Braid Outer Conductor and Black FEP Jacket PE-SR402FLJ](#)

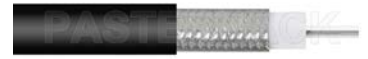

## Formable 141 Semirigid Coax Cable with Tinned Braid Outer Conductor and Black FEP Jacket

### RF Cables Technical Data Sheet

PE-SR402FLJ

#### Mechanical Specifications

Diameter	0.161 in [4.09 mm]
Weight	0.032 lbs/ft [0.05 Kg/m]
Min. Bend Radius (Installation)	0.315 in [8 mm]
Min. Bend Radius (Repeated)	1.575 in [40.01 mm]

#### Construction Specifications

Description	Material and Plating	Diameter
Inner Conductor	Copper, Silver1	0.036 in 0.91 mm
Conductor Type	Solid	
Dielectric	PTFE	0.117 in 2.97 mm
Outer Conductor	Tinned Copper Braid	0.139 in 3.53 mm
Jacket	FEP, Black	0.161 in [4.09 mm]

#### Environmental Specifications

##### Temperature

Operating Range	-65 to +150 deg C
Storage Range	10 to +35 deg C

**Compliance Certifications** (see [product page](#) for current document)

#### Plotted and Other Data

Notes:

Formable 141 Semirigid Coax Cable with Tinned Braid Outer Conductor and Black FEP Jacket from Pasternack Enterprises has same day shipment for domestic and International orders. Our RF, microwave and millimeter wave products maintain a 99.4% availability and are part of the broadest selection in the industry.

Click the following link (or enter part number in "SEARCH" on website) to obtain additional part information including price, inventory and certifications: [Formable PE-SR402FLJ Coax Cable with Tinned Copper Braid Outer Conductor and Black FEP Jacket PE-SR402FLJ](#)

URL: <https://www.pasternack.com/50-ohm-formable-141-semirigid-tinned-braid-outer-conductor-fep-jacket-black-pe-sr402flj-p.aspx>

# PE-SR402FLJ CAD Drawing

Formable 141 Semirigid Coax Cable with Tinned Braid  
Outer Conductor and Black FEP Jacket



**PE-SR402FLJ**

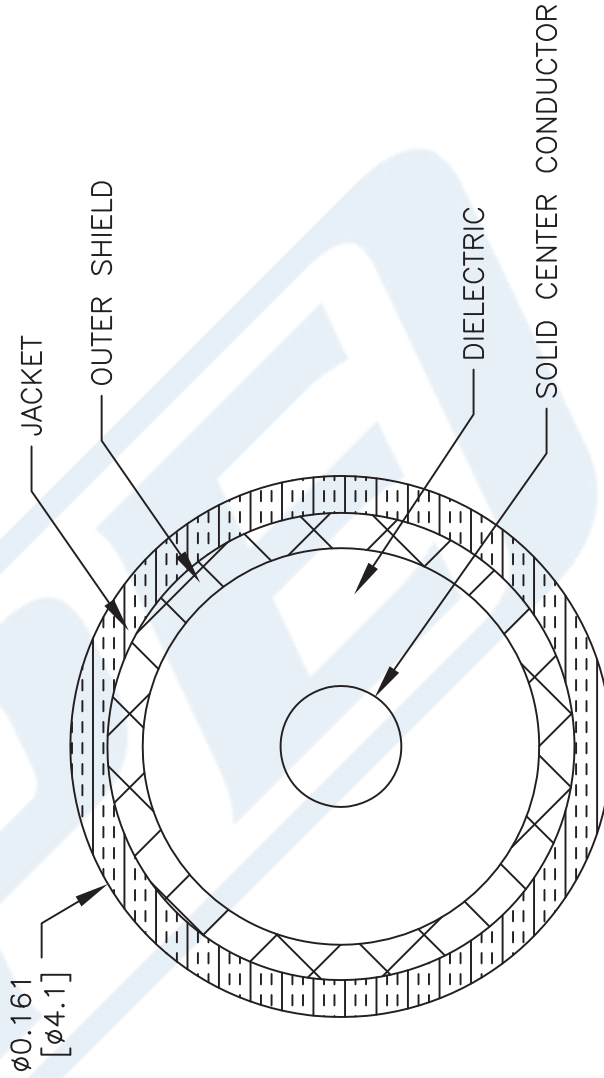

NOTES:  
1. UNLESS OTHERWISE SPECIFIED ALL DIMENSIONS ARE NOMINAL.  
2. ALL SPECIFICATIONS ARE SUBJECT TO CHANGE WITHOUT NOTICE AT ANY TIME.  
3. DIMENSIONS ARE IN INCHES [mm].

DWG TITLE  
**PE-SR402FLJ**

41742

SIZE A

SCALE N/A

CAD FILE 111716

FSCM NO. 53919

**PE PASTERNAK**  
THE ENGINEER'S RF SOURCE  
Pasternack Enterprises, Inc.  
P.O. Box 16759 | Irvine | CA | 92623  
Phone: (949) 261-1920 | Fax: (949) 261-7451  
Website: www.pasternack.com | E-Mail: sales@pasternack.com