



N Male Connector Crimp/Non-Solder Contact Attachment for LMR-195, PE-C195, LMR-200, PE-C200

RF Connectors Technical Data Sheet



EZ-195-NMH-X

Times Microwave Systems Connector Specification

Configuration

- N Male Connector
- MIL-STD-348
- 50 Ohms
- Straight Body Geometry
- Connector Interface Types: LMR-195, PE-C195, LMR-200, PE-C200

Features

- Max. Operating Frequency 6 GHz
- Good VSWR of 1.3:1
- Gold Plated Beryllium Copper Contact
- 50 μ m Thickness contact plating

Applications

- General Purpose Test
- Custom Cable Assemblies

Description

Pasternack's EZ-195-NMH-X type N, N, Standard, Connector is part of our full line of RF components available for same-day shipping. Our type N male connector operates up to a maximum frequency of 6 GHz and offers good VSWR of 1.3:1.

Our type N male connector EZ-195-NMH-X datasheet specifications and drawing with dimensions are shown below in this PDF. Pasternack's broad catalog of RF, microwave and millimeter wave connectors allows designers to configure and customize their signal connections however they like. Whether the need is to provide an I/O for a board design, or simply create a custom cable assembly configuration, Pasternack has the right connector for the job. Pasternack can also expertly build your custom cable assemblies for you and ship same-day.

Electrical Specifications

Description	Minimum	Typical	Maximum	Units
Frequency Range	DC		6	GHz
VSWR			1.3:1	
Insertion Loss			0.25	dB
Impedance		50		Ohms
Dielectric Withstanding Voltage (DC)			1,000	Vdc
Insulation Resistance	5,000			MOhms

Mechanical Specifications

Size

Length	1.27 in [32.26 mm]
Width	0.81 in [20.62 mm]
Height	0.81 in [20.62 mm]
Weight	0.08 lbs [35.83 g]
Mating Cycles	500 Cycles

Click the following link (or enter part number in "SEARCH" on website) to obtain additional part information including price, inventory and certifications: [N Male Connector Crimp/Non-Solder Contact Attachment for LMR-195, PE-C195, LMR-200, PE-C200 EZ-195-NMH-X](#)



N Male Connector Crimp/Non-Solder Contact Attachment for LMR-195, PE-C195, LMR-200, PE-C200

RF Connectors Technical Data Sheet

Material Specifications

Description	Material	Plating
Contact	Beryllium Copper	Gold 50 µin Thickness
Insulation	PTFE	
Outer Conductor	Brass	Tri-Metal 80 µin Thickness
Body	Brass	Tri-Metal 80 µin Thickness
Coupling Nut	Brass	Tri-Metal 80 µin Thickness

Environmental Specifications

Temperature

Operating Range

-40 to +125 deg C

Shock

MIL-STD 202G, Meth. 213, Cond. I

Vibration

MIL-STD 202G, Meth. 204, Cond.B

Thermal Shock

MIL-STD 202G, Meth. 107, Cond.B

Compliance Certifications (see [product page](#) for current document)

Plotted and Other Data

Notes:

N Male Connector Crimp/Non-Solder Contact Attachment for LMR-195, PE-C195, LMR-200, PE-C200 from Pasternack Enterprises has same day shipment for domestic and International orders. Our RF, microwave and millimeter wave products maintain a 99.4% availability and are part of the broadest selection in the industry.

Click the following link (or enter part number in "SEARCH" on website) to obtain additional part information including price, inventory and certifications: [N Male Connector Crimp/Non-Solder Contact Attachment for LMR-195, PE-C195, LMR-200, PE-C200 EZ-195-NMH-X](#)

URL: <https://www.pasternack.com/n-male-lmr-195-pe-c195-connector-ez-195-nmh-x-p.aspx>

The information contained in this document is accurate to the best of our knowledge and representative of the part described herein. It may be necessary to make modifications to the part and/or the documentation of the part, in order to implement improvements. Pasternack reserves the right to make such changes as required. Unless otherwise stated, all specifications are nominal. Pasternack does not make any representation or warranty regarding the suitability of the part described herein for any particular purpose, and Pasternack does not assume any liability arising out of the use of any part or documentation.

TIMES MICROWAVE SYSTEMS **EZ-195-NMH-X CAD Drawing**
 N Male Connector Crimp/Non-Solder Contact Attachment
 for LMR-195, PE-C195, LMR-200, PE-C200

REVISIONS			
REV.	DESCRIPTION	DATE	APPROVED
A	INITIAL RELEASE	6/16/2022	A. GANWANI

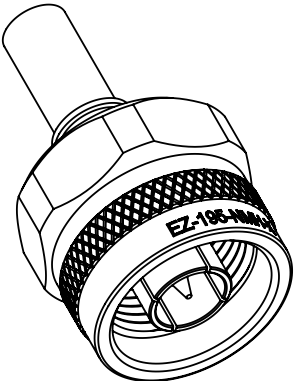
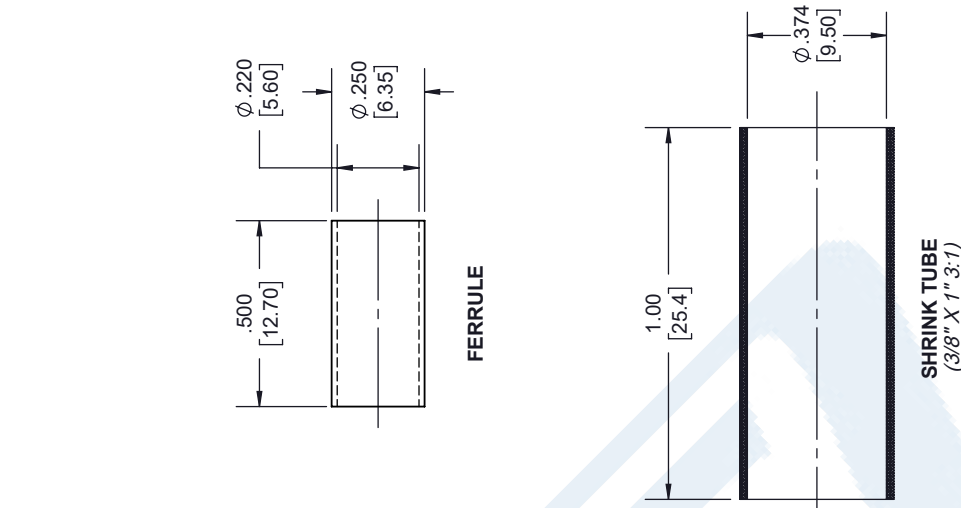

STRIPPING DIMENSIONS

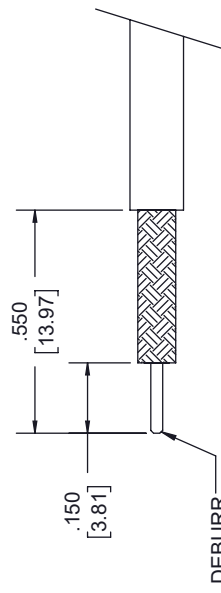

NOTES:

- CABLE ATTACHMENT:
 - OUTER: CRIMP.
 - INNER: SOLDER.
- CRIMP SIZE REQUIRED:
 - FERRULE: .213 [5.41] HEX. CRIMP TOOL.
 - CONTACT: SOLDER.

UNLESS OTHERWISE SPECIFIED LEADING DIMENSIONS ARE INCHES DIMENSIONS IN [] ARE MILLIMETERS

TOLERANCES:

X = ±.2	[5.08]	FRACTIONS	±.132
.XX = ±.02	[.51]	ANGLES	± 1°
.XXX = ±.005	[.13]	CABLE LENGTH (L)	TOLERANCES:
		L ≤ 12 [305]	= +1 [25] / -0
		12 [305] < L ≤ 60 [1524]	= +2 [51] / -0
		60 [1524] < L ≤ 120 [3048]	= +4 [102] / -0
		120 [3048] < L ≤ 300 [7620]	= +6 [152] / -0
		300 [7620] < L = +5% L / -0	

ALL DIMENSIONS SHOWN ARE FOR REFERENCE ONLY.

THIRD-ANGLE PROJECTION

THE INFORMATION AND DESIGN IN THIS DOCUMENT IS THE PROPERTY OF PASTERNAK CORPORATION ALL RIGHTS RESERVED.

SHEET 1 OF 1

SCALE N/A

PE PASTERNAK
 an INFINITO brand

Pasternack Enterprises, Inc.
 P.O. Box 16759, Irvine, CA 92623
 Phone: 1.949.261.1920 | 1.866.727.8376
 Fax: 1.949.261.7451
 Website: www.pasternack.com
 E-mail: sales@pasternack.com

SIZE A CAGE CODE A 53919 DRAWN BY K.DANG ITEM NO. EZ-195-NMH-X REV A

THESE COMMODITIES, TECHNOLOGY OR SOFTWARE WERE EXPORTED FROM THE UNITED STATES IN ACCORDANCE WITH THE EXPORT ADMINISTRATION REGULATIONS. DIVERSION CONTRARY TO U.S. LAW PROHIBITED.



N Male Connector Crimp/Non-Solder Contact Attachment for LMR-195, PE-C195, LMR-200, PE-C200

RF Connectors Technical Data Sheet



EZ-195-NMH-X

Times Microwave Systems Connector Specification

Configuration

- N Male Connector
- MIL-STD-348
- 50 Ohms
- Straight Body Geometry
- Connector Interface Types: LMR-195, PE-C195, LMR-200, PE-C200

Features

- Max. Operating Frequency 6 GHz
- Good VSWR of 1.3:1
- Gold Plated Beryllium Copper Contact
- 50 μ m Thickness contact plating

Applications

- General Purpose Test
- Custom Cable Assemblies

Description

Pasternack's EZ-195-NMH-X type N, N, Standard, Connector is part of our full line of RF components available for same-day shipping. Our type N male connector operates up to a maximum frequency of 6 GHz and offers good VSWR of 1.3:1.

Our type N male connector EZ-195-NMH-X datasheet specifications and drawing with dimensions are shown below in this PDF. Pasternack's broad catalog of RF, microwave and millimeter wave connectors allows designers to configure and customize their signal connections however they like. Whether the need is to provide an I/O for a board design, or simply create a custom cable assembly configuration, Pasternack has the right connector for the job. Pasternack can also expertly build your custom cable assemblies for you and ship same-day.

Electrical Specifications

Description	Minimum	Typical	Maximum	Units
Frequency Range	DC		6	GHz
VSWR			1.3:1	
Insertion Loss			0.25	dB
Impedance		50		Ohms
Dielectric Withstanding Voltage (DC)			1,000	Vdc
Insulation Resistance	5,000			MOhms

Mechanical Specifications

Size

Length	1.27 in [32.26 mm]
Width	0.81 in [20.62 mm]
Height	0.81 in [20.62 mm]
Weight	0.08 lbs [35.83 g]
Mating Cycles	500 Cycles

Click the following link (or enter part number in "SEARCH" on website) to obtain additional part information including price, inventory and certifications: [N Male Connector Crimp/Non-Solder Contact Attachment for LMR-195, PE-C195, LMR-200, PE-C200 EZ-195-NMH-X](#)



N Male Connector Crimp/Non-Solder Contact Attachment for LMR-195, PE-C195, LMR-200, PE-C200

RF Connectors Technical Data Sheet



EZ-195-NMH-X

Material Specifications

Description	Material	Plating
Contact	Beryllium Copper	Gold 50 µin Thickness
Insulation	PTFE	
Outer Conductor	Brass	Tri-Metal 80 µin Thickness
Body	Brass	Tri-Metal 80 µin Thickness
Coupling Nut	Brass	Tri-Metal 80 µin Thickness

Environmental Specifications

Temperature

Operating Range

-40 to +125 deg C

Shock

MIL-STD 202G, Meth. 213, Cond. I

Vibration

MIL-STD 202G, Meth. 204, Cond.B

Thermal Shock

MIL-STD 202G, Meth. 107, Cond.B

Compliance Certifications (see [product page](#) for current document)

Plotted and Other Data

Notes:

N Male Connector Crimp/Non-Solder Contact Attachment for LMR-195, PE-C195, LMR-200, PE-C200 from Pasternack Enterprises has same day shipment for domestic and International orders. Our RF, microwave and millimeter wave products maintain a 99.4% availability and are part of the broadest selection in the industry.

Click the following link (or enter part number in "SEARCH" on website) to obtain additional part information including price, inventory and certifications: [N Male Connector Crimp/Non-Solder Contact Attachment for LMR-195, PE-C195, LMR-200, PE-C200 EZ-195-NMH-X](#)

URL: <https://www.pasternack.com/n-male-lmr-195-pe-c195-connector-ez-195-nmh-x-p.aspx>

The information contained in this document is accurate to the best of our knowledge and representative of the part described herein. It may be necessary to make modifications to the part and/or the documentation of the part, in order to implement improvements. Pasternack reserves the right to make such changes as required. Unless otherwise stated, all specifications are nominal. Pasternack does not make any representation or warranty regarding the suitability of the part described herein for any particular purpose, and Pasternack does not assume any liability arising out of the use of any part or documentation.

TIMES MICROWAVE SYSTEMS **EZ-195-NMH-X CAD Drawing**
 N Male Connector Crimp/Non-Solder Contact Attachment
 for LMR-195, PE-C195, LMR-200, PE-C200

REVISIONS			
REV.	DESCRIPTION	DATE	APPROVED
A	INITIAL RELEASE	6/16/2022	A. GANWANI

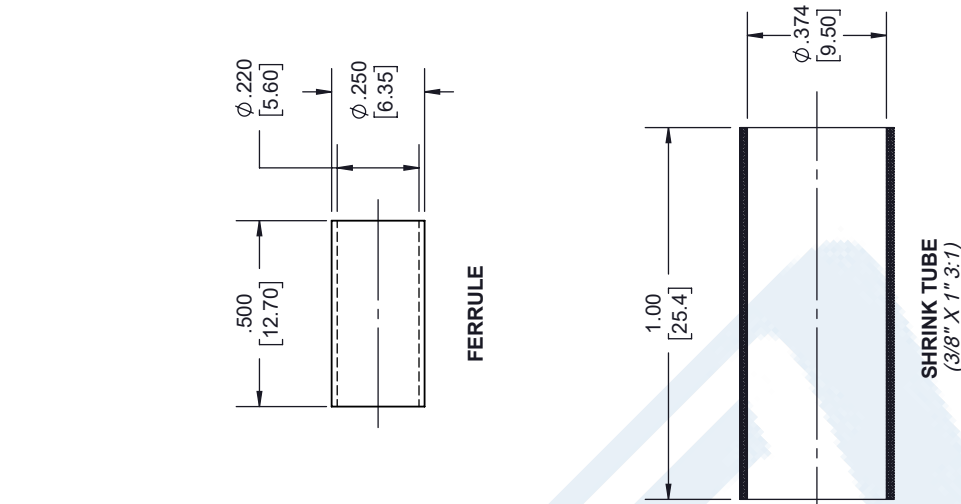

THIRD-ANGLE PROJECTION	THE INFORMATION AND DESIGN IN THIS DOCUMENT IS THE PROPERTY OF PASTERNAK CORPORATION. ALL RIGHTS RESERVED.
SHEET 1 OF 1	SCALE N/A

PE PASTERNAK
 an INFINITO brand

Pasternack Enterprises, Inc.
 P.O. Box 16759, Irvine, CA 92623
 Phone: 1.949.261.1920 | 1.866.727.8376
 Fax: 1.949.261.7451
 Website: www.pasternack.com
 E-mail: sales@pasternack.com

SIZE A CAGE CODE 53919 DRAWN BY K.DANG ITEM NO. EZ-195-NMH-X REV A

UNLESS OTHERWISE SPECIFIED LEADING DIMENSIONS ARE INCHES DIMENSIONS IN [] ARE MILLIMETERS

TOLERANCES:
 X = ±.2 [5.08] | FRACTIONS ±.132
 .XX = ±.02 [1.51] | ANGLES ± 1°
 .XXX = ±.005 [1.13] |
 CABLE LENGTH (L) TOLERANCES:
 L ≤ 12 [305] = +1 [25] / -0
 12 [305] < L ≤ 60 [1524] = +2 [51] / -0
 60 [1524] < L ≤ 120 [3048] = +4 [102] / -0
 120 [3048] < L ≤ 300 [7620] = +6 [152] / -0
 300 [7620] < L = +5% L / -0

ALL DIMENSIONS SHOWN ARE FOR REFERENCE ONLY.

- NOTES:
- CABLE ATTACHMENT:
 • OUTER: CRIMP.
 • INNER: SOLDER.
 - CRIMP SIZE REQUIRED:
 • FERRULE: .213 [5.41] HEX. CRIMP TOOL.
 • CONTACT: SOLDER.

THESE COMMODITIES, TECHNOLOGY OR SOFTWARE WERE EXPORTED FROM THE UNITED STATES IN ACCORDANCE WITH THE EXPORT ADMINISTRATION REGULATIONS. DIVERSION CONTRARY TO U.S. LAW PROHIBITED.



Flexible RG141 Coax Cable Single Shielded with Beige PTFE (Fiberglass reinforced) Jacket

RF Cables Technical Data Sheet

RG141A/U

Configuration

- Flexible Cable
- 1 Shield(s)

Electrical Specifications

Description	Minimum	Typical	Maximum	Units
Frequency Range	DC		10	GHz
Impedance		50 ±2		Ohms
Velocity of Propagation		70		%
Dielectric Withstanding Voltage (AC)			5,000	Vrms
Jacket Spark			2,000	Vrms
Nominal Capacitance		29.4 [96.46]		pF/ft [pF/m]

Performance by Frequency Band

Description	F1	F2	F3	F4	F5	Units
Frequency	0.01	0.1	1	5	10	GHz
Attenuation, Typ	1.2	3.9	13	36	62	dB/100ft
	3.94	12.8	42.65	118.11	203.41	dB/100m

Mechanical Specifications

Diameter	0.19 in [4.83 mm]
Weight	0.033 lbs/ft [0.05 Kg/m]

Construction Specifications

Description	Material and Plating	Diameter
Inner Conductor	Copper Clad Steel, Silver, 1 Strands	0.037 in [0.94 mm]
Conductor Type	Solid	
Dielectric	PTFE	0.116 in [2.95 mm]
First Shield	Silver Plated Copper	

Click the following link (or enter part number in "SEARCH" on website) to obtain additional part information including price, inventory and certifications: [Flexible RG141 Coax Cable Single Shielded with Beige PTFE \(FG\) Jacket RG141A/U](#)



Flexible RG141 Coax Cable Single Shielded with Beige PTFE (Fiberglass reinforced) Jacket

RF Cables Technical Data Sheet

RG141A/U

Jacket	PTFE (FG), Beige	0.19 in [4.83 mm]
--------	------------------	-------------------

Environmental Specifications

Temperature

Operating Range -55 to +200 deg C

Compliance Certifications (see [product page](#) for current document)

Plotted and Other Data

Notes:

Flexible RG141 Coax Cable Single Shielded with Beige PTFE (Fiberglass reinforced) Jacket from Pasternack Enterprises has same day shipment for domestic and International orders. Our RF, microwave and millimeter wave products maintain a 99.4% availability and are part of the broadest selection in the industry.

Click the following link (or enter part number in "SEARCH" on website) to obtain additional part information including price, inventory and certifications: [Flexible RG141 Coax Cable Single Shielded with Beige PTFE \(FG\) Jacket RG141A/U](#)

URL: <https://www.pasternack.com/flexible-0.190-rg141-50-ohm-coax-cable-ptfe-fr-jacket-rg141a-u-p.aspx>

The information contained in this document is accurate to the best of our knowledge and representative of the part described herein. It may be necessary to make modifications to the part and/or the documentation of the part, in order to implement improvements. Pasternack reserves the right to make such changes as required. Unless otherwise stated, all specifications are nominal. Pasternack does not make any representation or warranty regarding the suitability of the part described herein for any particular purpose, and Pasternack does not assume any liability arising out of the use of any part or documentation.

RG141A/U CAD Drawing

Flexible RG141 Coax Cable Single Shielded with Beige PTFE (Fiberglass reinforced) Jacket



NOTES:
1. UNLESS OTHERWISE SPECIFIED ALL DIMENSIONS ARE NOMINAL.
2. ALL SPECIFICATIONS ARE SUBJECT TO CHANGE WITHOUT NOTICE AT ANY TIME.
3. DIMENSIONS ARE IN INCHES [mm].

DWG TITLE
RG141A/U

REV. A FSCM NO. 53919

SCALE N/A

SIZE A

CAD FILE 022808-A

147

PE PASTERNAK®
Pasternack Enterprises, Inc.
P.O. Box 16759 | Irvine | CA | 92623
Phone: (949) 261-1920 | Fax: (949) 261-7451
Website: www.pasternack.com | E-Mail: sales@pasternack.com