

NOTICE OF PROPRIETARY RIGHTS THIS DOCUMENT CONTAINS CONFIDENTIAL TECHNICAL DATA, INCLUDING TRADE SECRETS, PROPRIETARY TO TIMES MICROWAVE SYSTEMS. DISCLOSURE OF THIS DATA IS EXPRESSLY CONDITIONED UPON YOUR ASSENT THAT ITS USE IS LIMITED TO USE WITHIN YOUR COMPANY ONLY. ANY OTHER USE IS STRICTLY PROHIBITED WITHOUT THE PRIOR WRITTEN CONSENT OF TIMES MICROWAVE SYSTEMS.

SYM	REVISION DESCRIPTION	DFTM	DATE	APPD	DATE
A	RELEASED FOR PRODUCTION	D. J. H.	5/30/07	J. D. B.	5/30/07
B	CHANGED PER CDC #27394	D. J. H.	10/2/07	J. D. B.	10/2/07
C	CHANGED PER CDC #27653	D. J. H.	12/6/07	J. D. B.	12/10/07
D	CHANGED PER CDC #28404	D. J. H.	5/27/08	J. D. B.	5/27/08

THIS CONNECTOR IS INDIVIDUALLY PACKAGED. FOR BULK PACKAGING, SEE 3190-2293BLK.

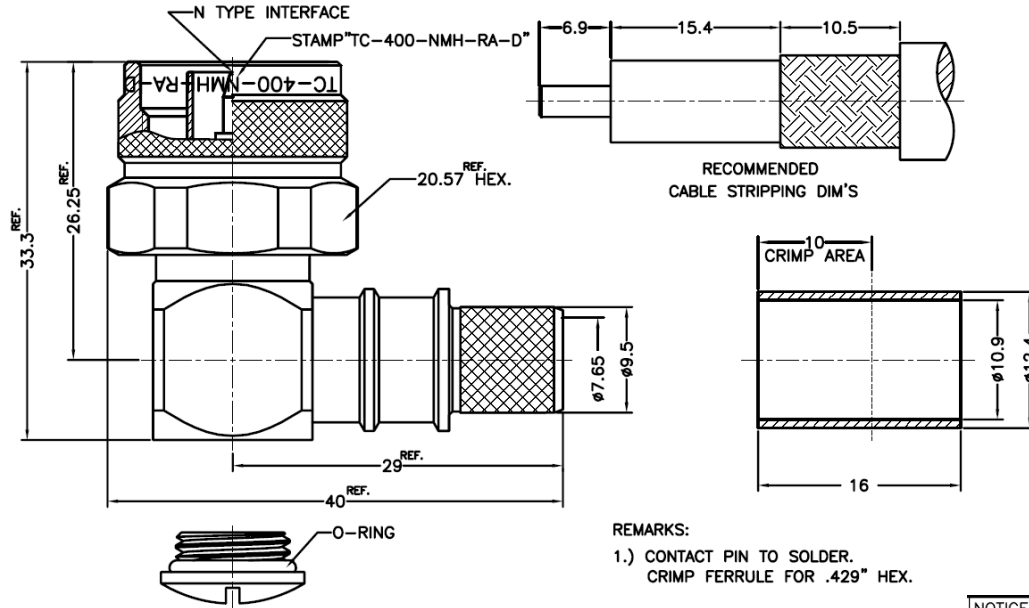

REMARKS:
1.) CONTACT PIN TO SOLDER.
CRIMP FERRULE FOR .429" HEX.

NOTICE: ALL PARTS MUST MEET TO RoHS REQUIREMENTS

MATERIALS AND PLATING UNIT: MICRO-INCHES			ELECTRICAL CHARACTERISTICS													
BODY,SHELL	BRASS C3604	ALBALOY(COPPER-TIN-ZINC) PL.80 MIN.	Impedance	50 Ω												
CONTACT PIN	BRASS C3604	GOLD 50/ COPPER	Voltage rating	1000V(rms)												
INSULATOR	TEFLON MIL-P-19468	RED	Frequency range	0~11GHz												
FERRULE	COPPER	ALBALOY(COPPER-TIN-ZINC) PL.80 MIN.	Dielectric withstanding voltage	1500V												
GASKET	SILICONE	RED	Contact resistance	Center contact: ≤1mΩ Outer contact≤0.25m Ω												
<table border="1"> <thead> <tr> <th colspan="2">(MECHANICAL CHARACTERISTICS)</th> </tr> </thead> <tbody> <tr> <td>Force to engage and disengage</td> <td>6 lbs MAX.</td> </tr> <tr> <td>Center contact retention force</td> <td>6 lbs MIN.</td> </tr> <tr> <td>Coupling torque</td> <td>30 in-lbs MIN.</td> </tr> <tr> <td>Coupling nut retention force</td> <td>100 lbs MIN.</td> </tr> <tr> <td>Durability</td> <td>≥ 500 cycles</td> </tr> </tbody> </table>			(MECHANICAL CHARACTERISTICS)		Force to engage and disengage	6 lbs MAX.	Center contact retention force	6 lbs MIN.	Coupling torque	30 in-lbs MIN.	Coupling nut retention force	100 lbs MIN.	Durability	≥ 500 cycles	Insulation resistance	≥5000MΩ
			(MECHANICAL CHARACTERISTICS)													
Force to engage and disengage	6 lbs MAX.															
Center contact retention force	6 lbs MIN.															
Coupling torque	30 in-lbs MIN.															
Coupling nut retention force	100 lbs MIN.															
Durability	≥ 500 cycles															
			Insertion loss	According as the cable												
			RF- leakage	-90 dB up to 3 GHz												
			VSWR	≤1.25 (DC-2.5GHz)												
			3rd Intermodulation	-												
			ENVIRONMENTAL CHARACTERISTICS													
			Temperature range	-55° C- +155° C												
			Thermal shock	US MIL- STD 202, Meth. 107, Cond. B												
			Vibration	US MIL- STD 202, Meth. 204, Cond. B												
			Shock	US MIL- STD 202, Meth. 213, Cond. I												
			Climatic class	IEC 60068 65/165/21												

MATERIAL: UNLESS OTHERWISE SPECIFIED	DFTM. D. J. H.		TIMES MICROWAVE SYSTEMS									
	DATE 5/30/07	DATE 5/30/07										
USED ON: 0	CHKD. J. D. B.		TC-400-NMH-RA-D 90° N MALE (INDIVIDUALLY PACKAGED) FOR LMR400 CABLE									
	DATE 5/30/07	APPD. J. D. B.										
SCALE: N/A	DWG. SIZE A	DO NOT SCALE DRAWING	<table border="1"> <tr> <td>CODE IDENT</td> <td>68999</td> <td>DATE</td> <td>5/30/07</td> <td>SHEET</td> <td>1 of 1</td> <td>SD3190-2293</td> <td>REV</td> <td>D</td> </tr> </table>	CODE IDENT	68999	DATE	5/30/07	SHEET	1 of 1	SD3190-2293	REV	D
CODE IDENT	68999	DATE	5/30/07	SHEET	1 of 1	SD3190-2293	REV	D				



N Male Connector Crimp/Solder Attachment for PE-B400, PE-B405, PE-C400, LMR-400, 0.400 inch

RF Connectors Technical Data Sheet

PE4550

Configuration

- N Male Connector
- MIL-STD-348A
- 50 Ohms
- Straight Body Geometry
- Connector Interface Types: PE-B400, PE-B405, PE-C400, LMR-400, .400 inch

Features

- Max. Operating Frequency 6 GHz
- Good VSWR of 1.3:1
- Silver Plated Brass Contact
- 70 μ m minimum contact plating

Applications

- General Purpose Test
- Custom Cable Assemblies

Description

Pasternack's PE4550 type N male connector with crimp/solder attachment for PE-B400, PE-B405, PE-C400, LMR-400 and .400 inch is part of our full line of RF components available for same-day shipping. Our type N male connector operates up to a maximum frequency of 6 GHz and offers good VSWR of 1.3:1.

Our type N male connector PE4550 datasheet specifications and drawing with dimensions are shown below in this PDF. Pasternack's broad catalog of RF, microwave and millimeter wave connectors allows designers to configure and customize their signal connections however they like. Whether the need is to provide an I/O for a board design, or simply create a custom cable assembly configuration, Pasternack has the right connector for the job. Pasternack can also expertly build your custom cable assemblies for you and ship same-day.

Electrical Specifications

Description	Minimum	Typical	Maximum	Units
Frequency Range	DC		6	GHz
VSWR			1.3:1	
Operating Voltage (AC)			600	Vrms

Mechanical Specifications

Size

Length	1.505 in [38.23 mm]
Width/Dia.	0.827 in [21.01 mm]
Weight	0.071 lbs [32.21 g]

Click the following link (or enter part number in "SEARCH" on website) to obtain additional part information including price, inventory and certifications: [N Male Connector Crimp/Solder Attachment for PE-B400, PE-B405, PE-C400, LMR-400, 0.400 inch PE4550](#)



N Male Connector Crimp/Solder Attachment for PE-B400, PE-B405, PE-C400, LMR-400, 0.400 inch

RF Connectors Technical Data Sheet

PE4550

Material Specifications

Description	Material	Plating
Contact	Brass	Silver 70 µin minimum
Insulation	PTFE	
Body	Brass	Nickel 100 µin minimum
Coupling Nut	Brass	Nickel 100 µin minimum
Crimp Sleeve	Brass	Nickel

Environmental Specifications

Temperature

Operating Range -65 to +165 deg C

Compliance Certifications (see [product page](#) for current document)

Plotted and Other Data

Notes:

N Male Connector Crimp/Solder Attachment for PE-B400, PE-B405, PE-C400, LMR-400, 0.400 inch from Pasternack Enterprises has same day shipment for domestic and International orders. Our RF, microwave and millimeter wave products maintain a 99.4% availability and are part of the broadest selection in the industry.

Click the following link (or enter part number in "SEARCH" on website) to obtain additional part information including price, inventory and certifications: [N Male Connector Crimp/Solder Attachment for PE-B400, PE-B405, PE-C400, LMR-400, 0.400 inch PE4550](#)

URL: <https://www.pasternack.com/n-male-standard-pe-b400-pe-b405-pe-c400-connector-pe4550-p.aspx>

The information contained in this document is accurate to the best of our knowledge and representative of the part described herein. It may be necessary to make modifications to the part and/or the documentation of the part, in order to implement improvements. Pasternack reserves the right to make such changes as required. Unless otherwise stated, all specifications are nominal. Pasternack does not make any representation or warranty regarding the suitability of the part described herein for any particular purpose, and Pasternack does not assume any liability arising out of the use of any part or documentation.

PE4550 CAD Drawing

N Male Connector Crimp/Solder Attachment for PE-B400,
PE-B405, PE-C400, LMR-400, 0.400 inch

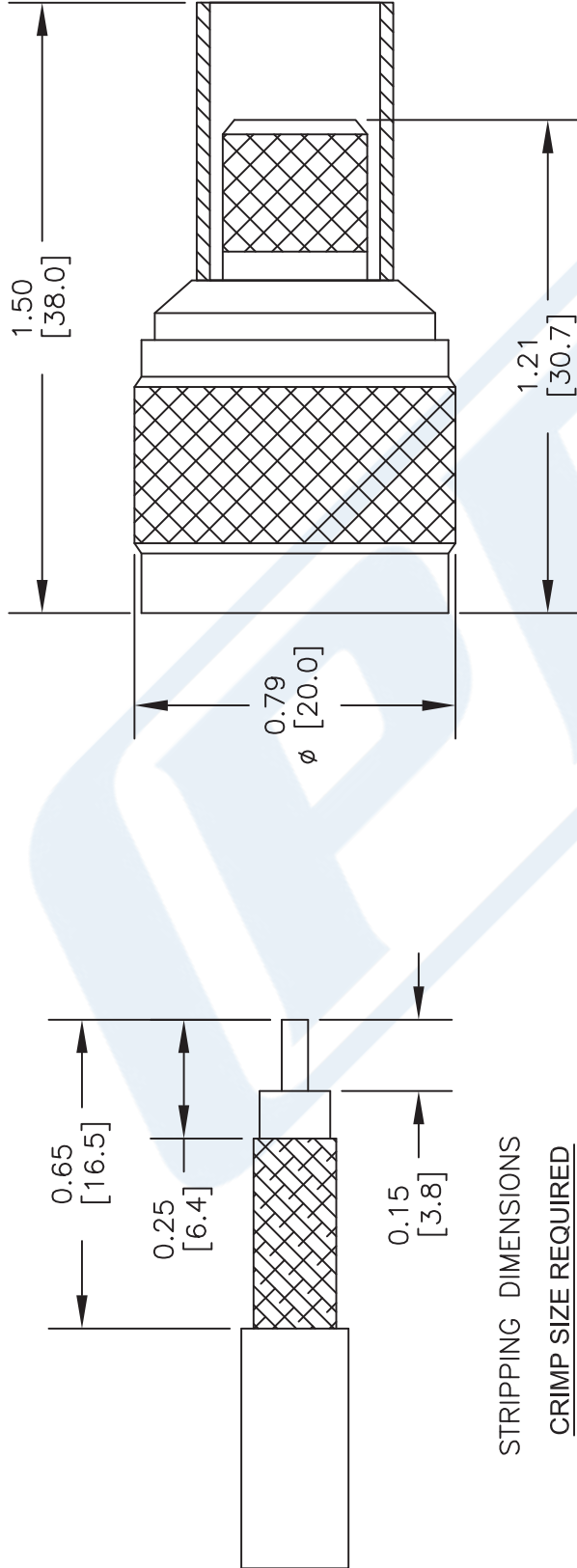

DWG TITLE

PE4550

FSCM NO. 53919

NOTES:
1. UNLESS OTHERWISE SPECIFIED ALL DIMENSIONS ARE NOMINAL.
2. ALL SPECIFICATIONS ARE SUBJECT TO CHANGE WITHOUT NOTICE AT ANY TIME.
3. DIMENSIONS ARE IN INCHES [mm].
4. FITS MIL-C-17 AND EQUIVALENT CABLES.

CAD FILE 052714

SCALE N/A

SIZE A

2233

(PE) PASTERNAK®
THE ENGINEER'S RF SOURCE

Pasternack Enterprises, Inc.
P.O. Box 16759 | Irvine | CA | 92623
Phone: (949) 261-1920 | Fax: (949) 261-7451
Website: www.pasternack.com | E-Mail: sales@pasternack.com

Low Loss Flexible LMR-240-LLPX Rated Coax Cable with Fluoropolymer Jacket



LMR-240-LLPX

Configuration

- Low Loss Flexible Cable
- 1 Shield(s)

Features

- Max Operating Frequency of 8 GHz
- Phase Velocity 76% VoP
- Max Operating Temperature +125°C

Applications

- Laboratory Applications
- General Purpose RF Interconnect

Description

The LMR-240-LLPX part number from Pasternack is a low-loss coax cable that is flexible. Pasternack flexible coax RF cable has an impedance of 50 Ohm and a PTFE dielectric. Our LMR-240-LLPX coax cable is constructed with a 0.21-inch jacket made of polyethylene. This RF coaxial cable is ideal for laboratory applications and general purpose RF interconnect applications. This red-colored low-loss coax cable has a nominal capacitance of 26.7 pF/Ft.

This LMR-240-LLPX flexible RF cable has a minimum RF shielding of 90 dB. Our coax cable from Pasternack has a maximum frequency of 8 GHz. Additional specifications for this LMR-240-LLPX RF coaxial cable are on our downloadable PDF datasheet above. This low-loss RF cable has a one-time minimum bend radius of 0.75 inches and a repeat minimum bend radius of 2.5 inches.

Our LMR-240-LLPX coax cable can operate at temperatures ranging from -40 to 125 degrees C. Our coax cable has a typical loss/attenuation of 1.4, 3.1, 5.4, 7.6, 9.9, 11.5, 12.9, 15.1, 20, and 24.3 dB/100ft at frequencies of 30 MHz, 150 MHz, 450 MHz, 900 MHz, 1.5 GHz, 2 GHz, 2.5 GHz, 3.4 GHz, 5.8 GHz, and 8 GHz, respectively. The LMR-240-LLPX flexible RF cable has a copper center conductor.

Pasternack LMR-240-LLPX low-loss coax cables are part of our RF, microwave, and millimeter wave components. These flexible cables and our other RF parts are available for same-day shipping worldwide. Custom RF cable assemblies using LMR-240-LLPX, or other coax can be built and shipped the same business day as well.

Electrical Specifications

Description	Minimum	Typical	Maximum	Units
Frequency Range	DC		8	GHz
Impedance		50		Ohms
Velocity of Propagation		76		%
Shielding Effectiveness	90			dB
Operating Voltage (DC)			1,500	Vdc
Jacket Spark			5,000	Vrms
Inner Conductor DC Resistance			4	Ohms/1000ft
Outer Conductor DC Resistance			3.9	Ohms/1000ft
Nominal Capacitance		26.7 [87.6]		pF/ft [pF/m]

Low Loss Flexible LMR-240-LLPX Rated Coax Cable with Fluoropolymer Jacket

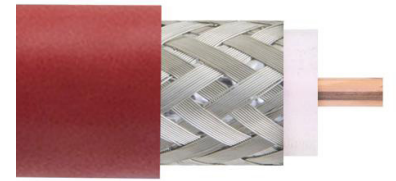

LMR-240-LLPX

Electrical Specifications

Description	Minimum	Typical	Maximum	Units
Nominal Inductance		0.067 [0.22]		uH/ft [uH/m]
Input Power (Peak)			5.6	kWatts

Performance by Frequency Band

Description	F1	F2	F3	F4	F5	Units
Frequency	0.03	0.15	0.45	0.9	1.5	GHz
Attenuation, Typ	1.4	3.1	5.4	7.6	9.9	dB/100ft
	4.59	10.17	17.72	24.93	32.48	dB/100m

Description	F6	F7	F8	F9	F10	Units
Frequency	2	2.5	3.4	5.8	8	GHz
Attenuation, Typ	11.5	12.9	15.1	20	24.3	dB/100ft
	37.73	42.32	49.54	65.62	79.72	dB/100m

Mechanical Specifications

Diameter	0.214 in [5.44 mm]
Weight	0.035 lbs/ft [0.05 kg/m]
Min. Bend Radius (Installation)	0.75 in [19.05 mm]
Min. Bend Radius (Repeated)	2.5 in [63.5 mm]
Tensile Strength	60 lbs [27.22 kg]
Flat Plate Crush	85 lbs/in [1.52 kg/mm]

Construction Specifications

Description	Material and Plating	Diameter
Inner Conductor	Copper, Strand	0.051 in [1.3 mm]
Dielectric	PTFE	0.15 in [3.81 mm]
First Shield	Tinned Copper Braid	0.178 in [4.52 mm]
Outer Conductor	Aluminum Tape	0.155 in [3.94 mm]
Jacket	Fluoropolymer	0.214 in [5.44 mm]

Environmental Specifications

Temperature	
Operating Range	-40 to +125 deg C
Installation Range	-40 to +125 deg C
Storage Range	-40 to +125 deg C

Low Loss Flexible LMR-240-LLPX Rated Coax Cable with Fluoropolymer Jacket



LMR-240-LLPX

Compliance Certifications (see [product page](#) for current document)

Plotted and Other Data

Notes:

Low Loss Flexible LMR-240-LLPX Rated Coax Cable with Fluoropolymer Jacket from Pasternack Enterprises has same day shipment for domestic and International orders. Our RF, microwave and millimeter wave products maintain a 99.4% availability and are part of the broadest selection in the industry.

Click the following link (or enter part number in "SEARCH" on website) to obtain additional part information including price, inventory and certifications: [Low Loss Flexible LMR-240-LLPX Rated Coax Cable with Fluoropolymer Jacket LMR-240-LLPX](#)

URL: <https://www.pasternack.com/low-loss-flexible-lmr240llpx-fluoropolymer-jacket-lmr-240-llpx-p.aspx>

The information contained within this document is accurate to the best of our knowledge and representative of the part described herein. It may be necessary to make modifications to the part and/or the documentation of the part in order to implement improvements. Pasternack Enterprises reserves the right to make such changes as required. Unless otherwise stated, all specifications are nominal. Pasternack Enterprises does not make any representation or warranty regarding the suitability of the part described herein for any particular purpose, and Pasternack Enterprises does not assume liability arising out of the use of any part or document.

LMR-240-LLPX CAD Drawing

Low Loss Flexible LMR-240-LLPX Rated Coax Cable with Fluoropolymer Jacket

